

# ArmWrestling

## OPERATION MANUAL

MODEL NO: CHV1-UP

MODEL NO: CHV1-UP-US

Nintendo®

—WARNING—

This equipment generates, uses, and can radiate radio frequency energy and if not installed and used in accordance with the instructions manual, may cause interference to radio communications. It has been tested and found to comply with the limits for a Class A computing device pursuant to Subpart J of Part 15 of FCC Rules, which are designed to provide reasonable protection against such interference when operated in a commercial environment. Operation of this equipment in a residential area is likely to cause interference in which case the user at his own expense will be required to take whatever measures may be required to correct the interference.

—WARNING—

Use of non-Nintendo parts or modifications of your Nintendo game circuitry may adversely affect the safety of your game, and may cause injury to your players.

## Contents

1. Location Setup .....	1
A. Game Inspection .....	1
B. Game Installation .....	2
(1) Voltage Selection .....	3
(2) Power On/Off Switch .....	4
(3) Grounding of Game .....	4
(4) Adjustment of Video Monitor .....	5-6
2. Option Switch Settings .....	7
A. Game Price Settings .....	8
B. Game Option Settings .....	8
3. Self-Test and Bookkeeping .....	9
4. Maintenance and Repair .....	10
A. Fuse Replacement .....	10
B. Cleaning .....	10
C. Operation Panel .....	10-11
D. Video Monitor Removal .....	12-13
E. Game PCB Removal .....	14
5. Radio Frequency Interference .....	14
6. Wiring and Connection .....	15-16
7. Parts Lists .....	17
A. CHV1-UP Game Cabinet Assembly .....	17-20
B. CHV1-UP Operation Panel Assembly .....	21-22
C. CHV1-UP Wiring Harnesses .....	22
D. CHV1-CPU PCB Assembly (For 01 and 02 versions) .....	23-25
E. CHV1-VIDEO PCB Assembly (For 01 version) .....	25-27
F. CHV1-VIDEO PCB Assembly (For 02 version) .....	27-28
G. CHV1-BAK PCB Assembly .....	29-30
H. 054-FCC PCB Assembly .....	30
I. PP-1000A Power Supply Assembly .....	31-32
J. CHV1-UP Fuses .....	32

# 1. Location Setup

## A. Game Inspection

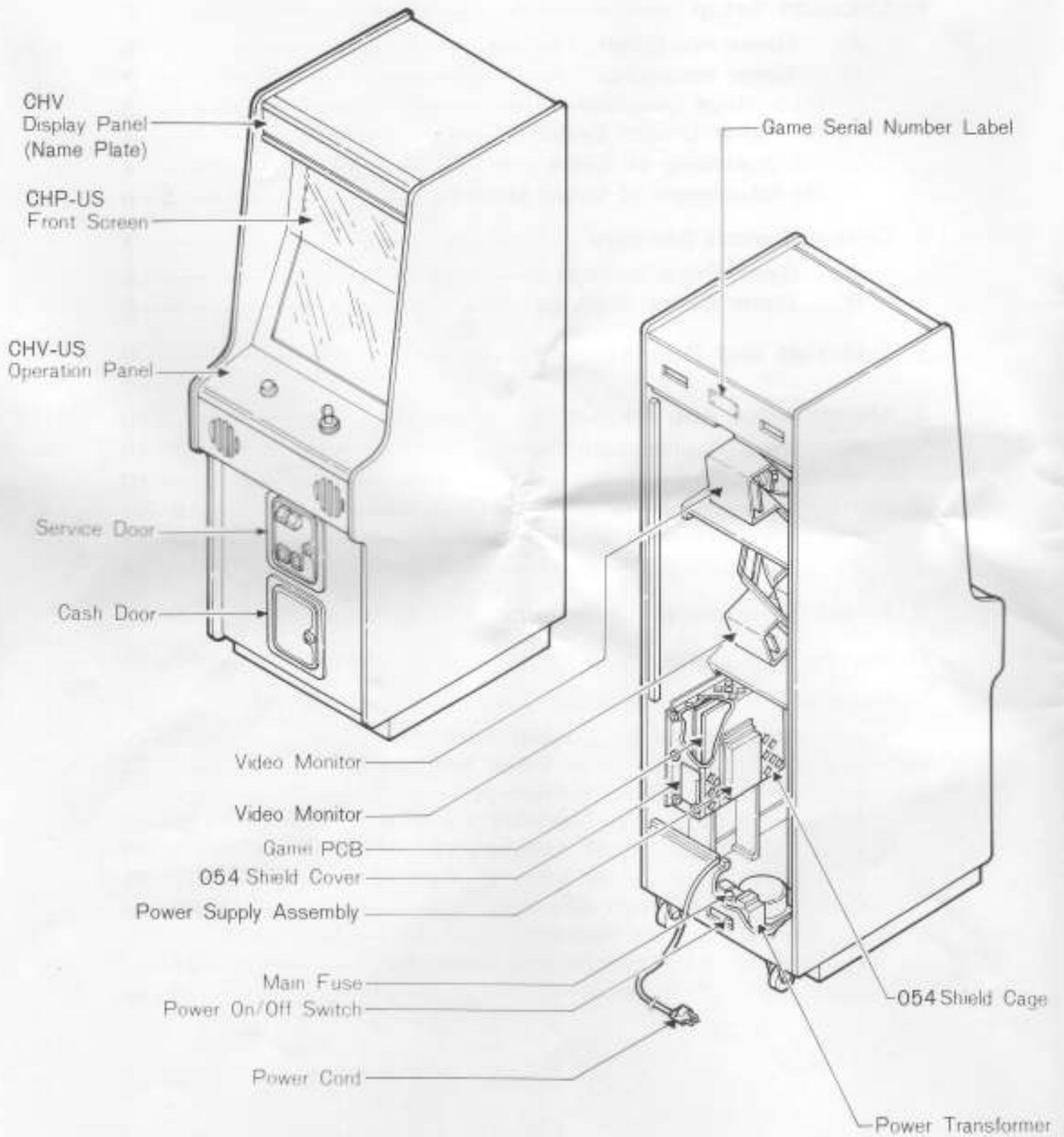

Fig. 1 Game Overview

**WARNING**

Check before plugging the game in !

The game "Arm Wrestling" is shipped ready for operation, but a last visual check should be made to insure the final touch of quality control. Please check the following to help us insure that your new game was delivered to you in good condition.

- (1) Check the exterior of the game for shipping damage, dents, chips, or broken parts.
- (2) Remove the screws on the Rear Door Panel.
- (3) Unlock and open the Rear Door Panel, as well as the Service Door inspect the interior of the game as follows:
  - (a) Check that Plug-in connectors are firmly connected.
  - (b) Check that Plug-in integrated circuits on the Game PCB are firmly connected in their sockets.
  - (c) Check that all major subassemblies such as the Power Supply, Operation Panel, and Video Monitor are properly mounted.
  - (d) Remove the tie-wrap that holds the coiled Power Cord on the inside cabinet wall. Check the cord for any cuts or dents in the insulation.

## B. Game Installation

Fig. 2 Installation Requirements

---

Power	:	170 watts
Temperature	:	0 to 38 deg.C (32 to 100 deg.F)
Humidity	:	Not over 95% relative
Space required	:	63 (W) × 90 (D)cm (24 3/4 × 35 1/2 in.)
Height	:	189 cm (74 1/2 in.)

---

### (1) Voltage Selection

Before plugging in your game, make sure the Terminal Block of the Power Transformer is correct for your location's line voltage.

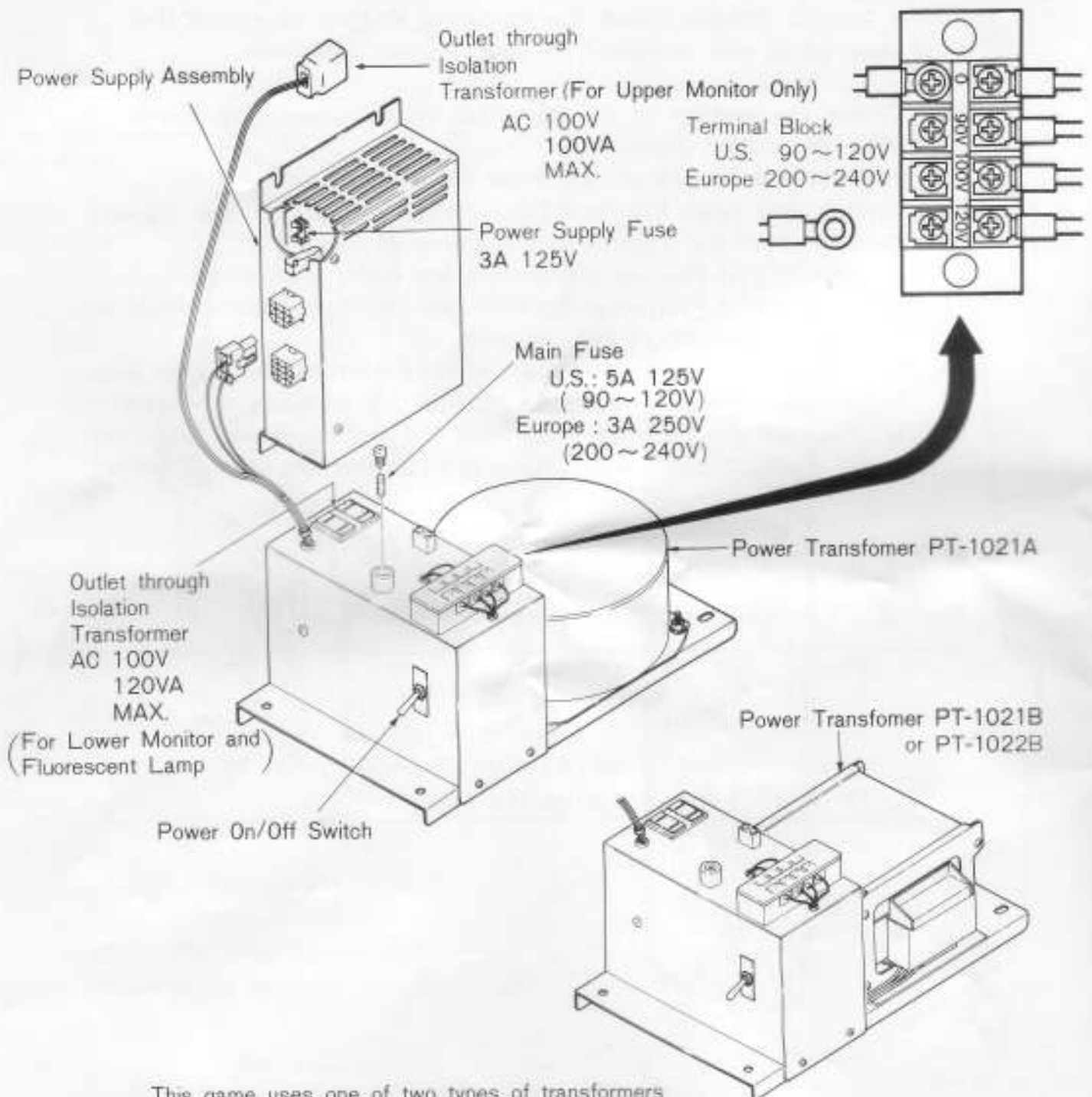

This game uses one of two types of transformers which are different in appearance but identical in function. The two types can be interchanged.

Fig. 3 Power Supply Assembly, Power Transformer and Voltage Selection

**(2) Power On/Off Switch**

A Power On/Off Switch is located in the rear of the game at the bottom center of the cabinet. See Fig. 1.

If the results of the preceding steps are satisfactory, you are ready to plug the game in, and set the Power On/Off Switch to the "On" position.

**WARNING**

This game **MUST** be grounded. Failure to do so may result in destruction of electronic components.

**(3) Grounding of Game (Use only if 3 wire outlet is unavailable.)  
See Fig. 4**

- (a) A grounding wire should be connected to a grounding bar or a metal pipe which is firmly inserted into the ground.
- (b) Do not connect the grounding to a water pipe, because polyvinyl-chloride pipes are sometimes used in water lines, and the electronic continuity to the ground may be interrupted.
- (c) Absolutely do not connect the grounding wire to a gas pipe, as this can be extremely dangerous.

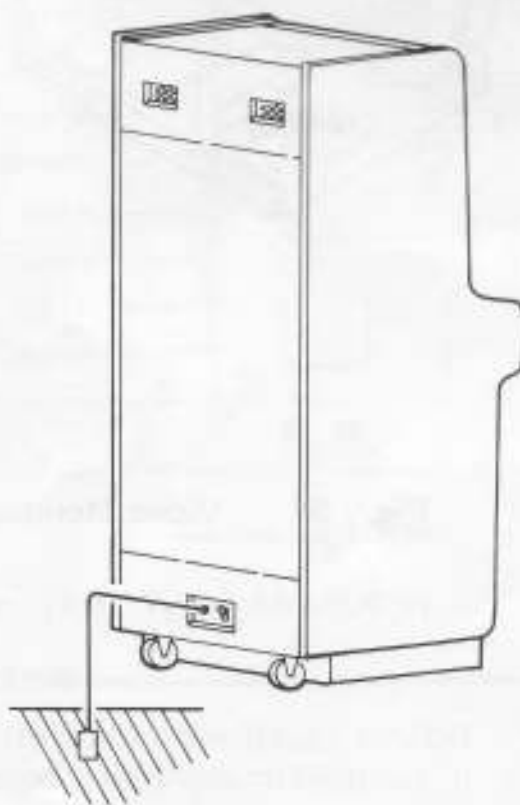

**Fig. 4**      **Grounding of Game**

#### (4) Adjustment of Video Monitor

This game uses one of four types of Video Monitors which are different in appearance but identical in function. The four types can be interchanged.

- (a) Video Monitor : [32 Type] 20-EZV(R-C)
- (b) Video Monitor : [33 Type] 20-EZV(R-C)
- (c) Video Monitor : [35 Type] 20-Z2AW

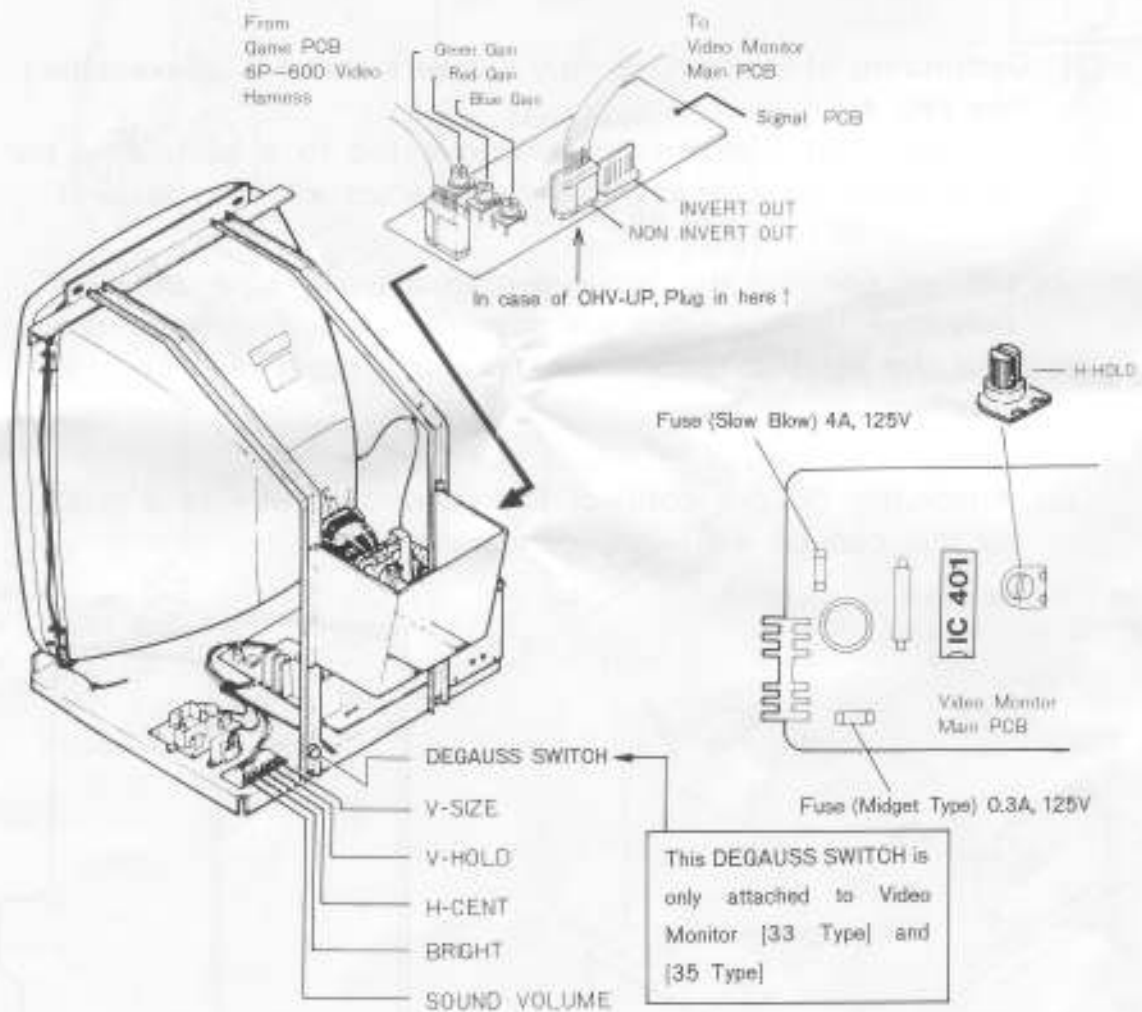

Fig. 5 Video Monitor : [32 Type] 20-EZV(R-C)  
[33 Type] 20-EZV(R-C)  
[35 Type] 20-Z2AW

#### WARNING

Do not touch the inside of the Video Monitor.  
It contains many parts supplied with high voltage.



(d) Video Monitor : [Y51 Type] XM-2001N

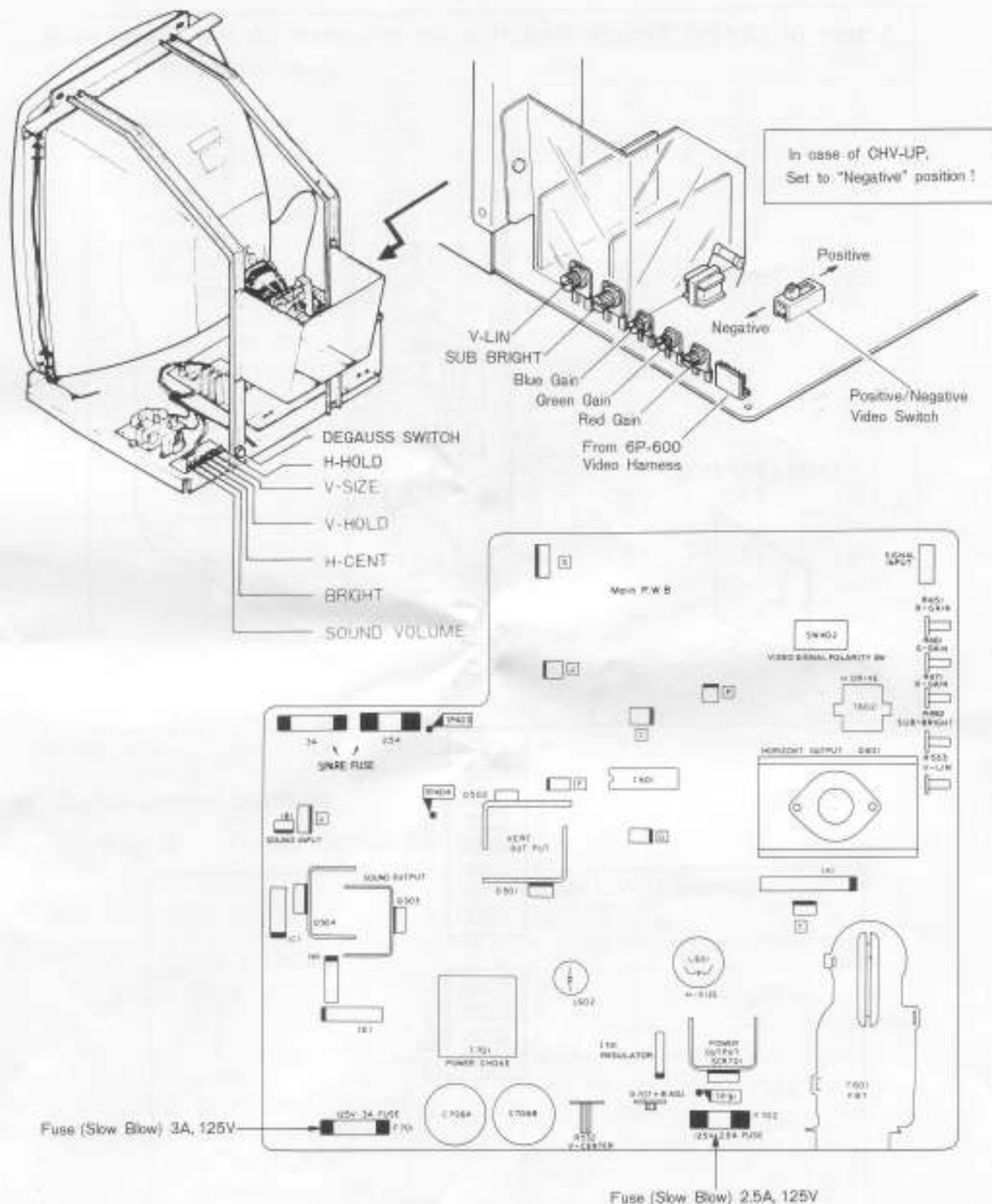

Fig. 6 Video Monitor : [Y51 Type] XM-2001N

WARNING

Do not touch the inside of the Video Monitor.  
It contains many parts supplied with high voltage.

## 2. Option Switch Settings

A pair of Option Toggle Switches are mounted on the Game PCB.

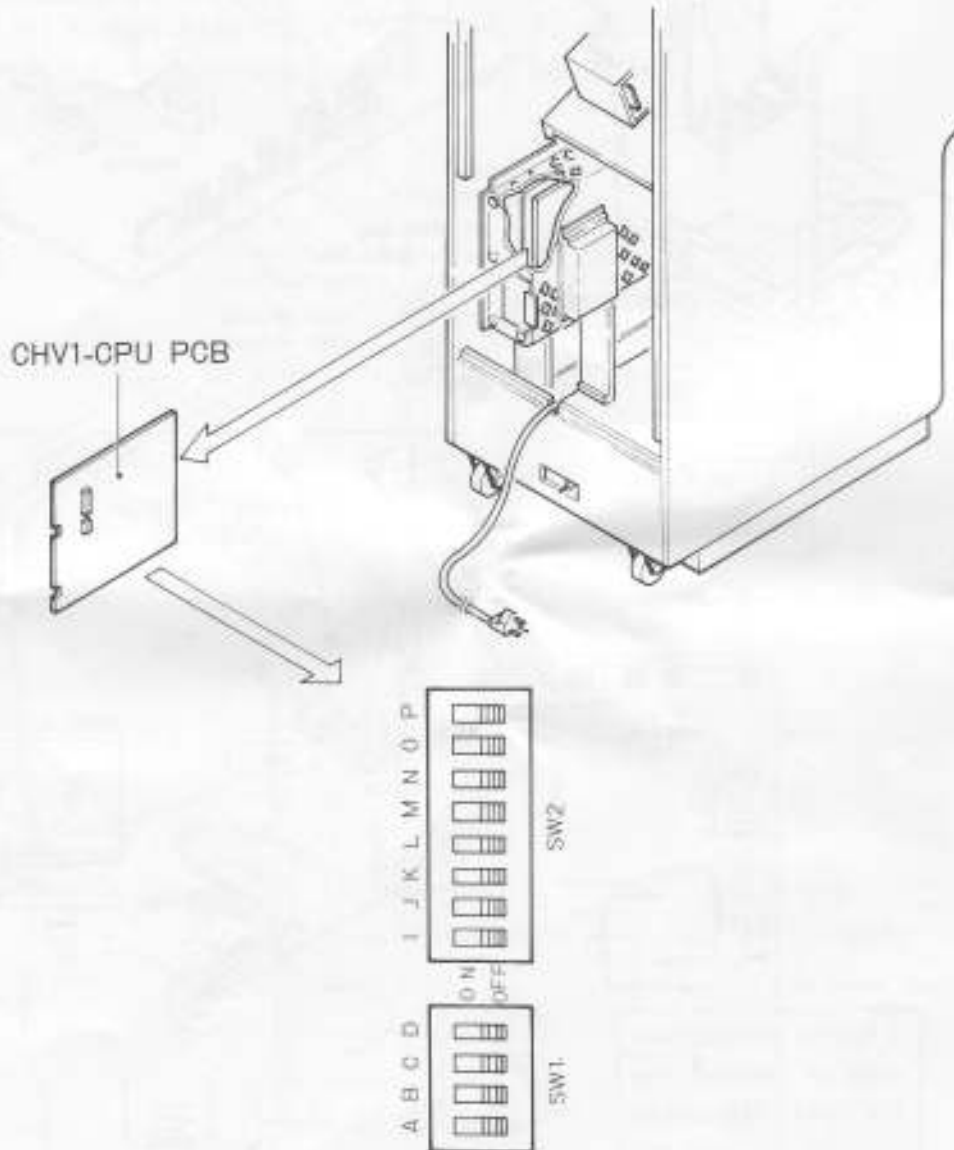

Fig. 7 Option Toggle Switches

### A. Game Price Settings

Fig. 8 Game Price Settings

Play/coin	Toggle Settings				
	SW1				SW2
	A	B	C	D	N
1/6	OFF	OFF	OFF	ON	OFF
2/5	OFF	ON	OFF	OFF	ON
1/5	OFF	OFF	ON	OFF	OFF
5/4	ON	OFF	OFF	OFF	ON
3/4	ON	OFF	ON	ON	ON
1/4	ON	ON	OFF	OFF	OFF
5/3	OFF	OFF	OFF	OFF	ON
4/3	OFF	ON	ON	ON	OFF
2/3	ON	OFF	OFF	ON	OFF
1/3	OFF	OFF	ON	ON	OFF
5/2	ON	OFF	ON	ON	OFF
3/2	ON	ON	OFF	ON	OFF
1/2	ON	OFF	OFF	OFF	OFF
1/1	OFF	OFF	OFF	OFF	OFF
2/1	OFF	ON	OFF	OFF	OFF
3/1	ON	OFF	ON	OFF	OFF
4/1	OFF	ON	ON	OFF	OFF
5/1	OFF	ON	OFF	ON	OFF
6/1	ON	ON	ON	OFF	OFF
Freeplay	ON	ON	ON	ON	OFF

### B. Game Option Settings

Fig. 9 Game Option Settings

	Toggle (SW2) Settings							
	I	J	K	L	M		O	P
Game Difficulty								
Easy (0)	OFF	OFF						
↓ (1)	ON	OFF						
↓ (2)	OFF	ON						
Hard (3)	ON	ON						
3 Rematches Allowed							OFF	
7 Rematches Allowed							ON	
Self-Test/Game								
Game (0)								OFF
Self-Test (1)								ON

#### WARNING

All the Option Switch Settings MUST be done with Power Off.

### 3. Self-Test and Bookkeeping

#### (1) Entry

There are two ways to enter Self-Test and Bookkeeping modes.

- (a) While pressing the Service Switch, set the Power On/Off Switch to the "On" position. The hall of fame RAM is now possible to reset.
- (b) Set for Self-Test Mode with Toggle P (SW2) on the Game PCB. And set the Power On/Off Switch to the "On" position.

(2) Self-Test and Bookkeeping are self-explanatory on the Video Monitor as follows.

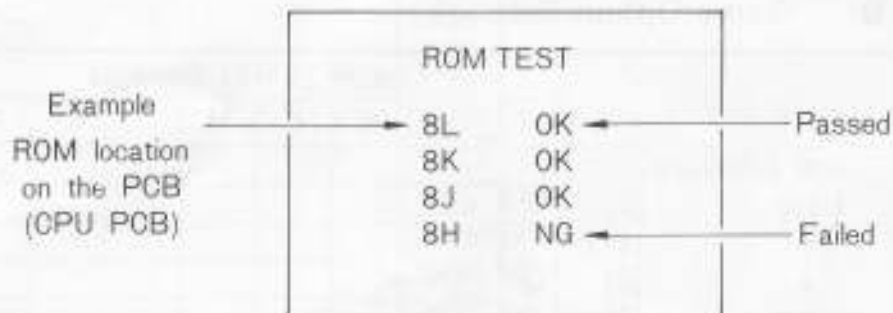
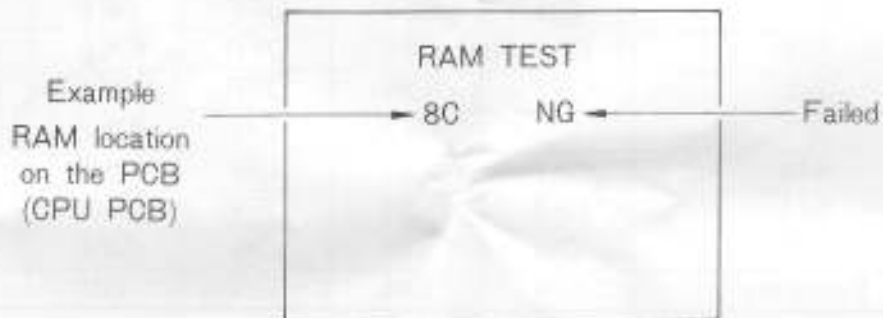

## 4. Maintenance and Repair

### A. Fuse Replacement

This game contains 4 fuses. Replace fuses only with the same type as listed below.

Fig 10 Specification of Fuses

(1) Main Fuse	U.S. : 5A 125V ( 90~120V) Europe : 3A 250V (200~240V) See Fig. 1 and 3
(2) Power Supply Fuse	3A 125V(Midget) See Fig. 3
(3) Video Monitor Fuses	
(a) [32 Type] 20-EZV(R-C)	4A 125V(Slow Blow) 0.3A 125V(Midget) See Fig. 5
(b) [33 Type] 20-EZV(R-C)	
(c) [35 Type] 20-Z2AW	2.5A 125V(Slow Blow) 3A 125V(Slow Blow) See Fig. 6
(d) [Y51 Type] XM-2001N	

### B. Cleaning

The exterior of the game, all metal parts and all plastic parts can be cleaned with a nonabrasive cleanser. You should be careful when cleaning the glass or plastic parts. A dry cloth may cause scratches which will result in a foggy appearance.

### C. Operation Panel

#### (1) Operation Panel Removal

Before repairing or replacing any switches or Complete A2PL Controller Ass'y. on the Operation Panel, unplug the game. Open the Service Door, which are reach through the opening, and unlock the Clamps, located at each end on the underside of the Operation Panel. See Fig. 13.

#### (2) Micro-switch Replacement

Whenever you replace any micro-switch on the Operation Panel, a switch gap adjustment is needed as shown in Fig. 11. Also, see Fig. 19. for layout of Control Panel Switches.

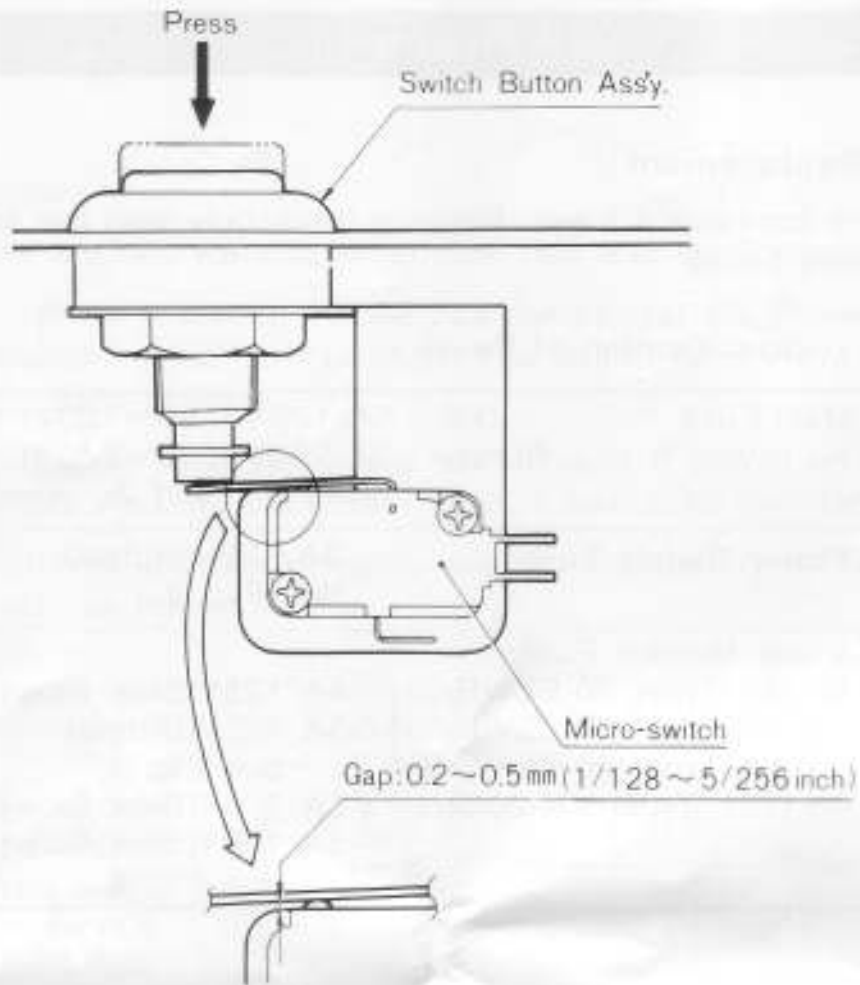

Fig. 11 Switch gap adjustment

(3) Lubrication for Complete A2PL Controller Ass'y.

To maintain the Complete A2PL Controller Ass'y. in good condition, lubricate the pillow balls and 2 way Guide Plate approx. every 3 months. See Fig. 12.

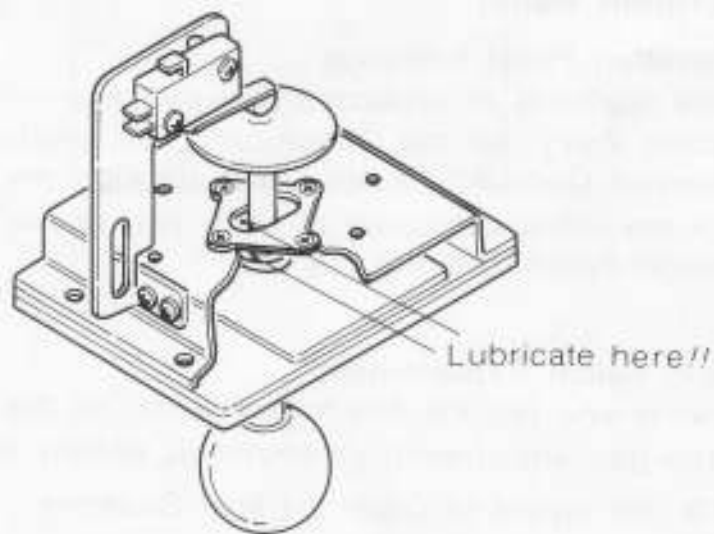

Fig. 12 Lubrication points

## D. Video Monitor Removal

### (1) Front Screen Removal

First remove the Operation Panel and then pull the Front Screen toward you.

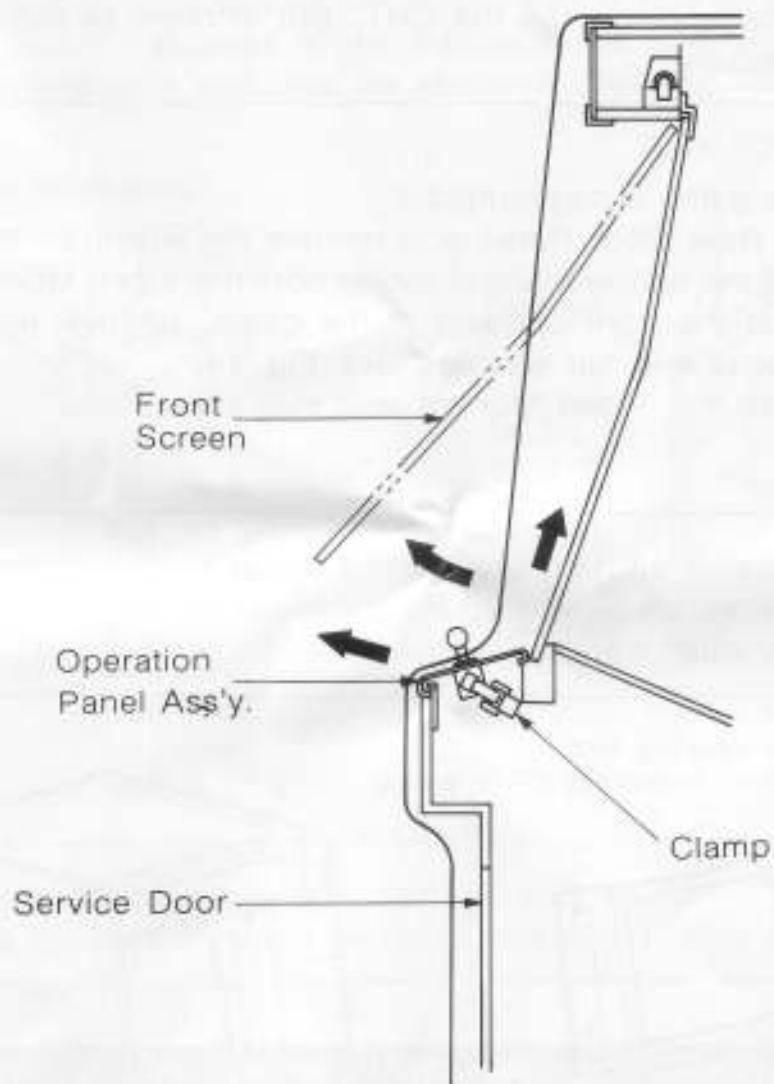

Fig. 13 Front Screen and Operation Panel Ass'y. Removal

## (2) Video Monitor Removal

If you need to remove the Video Monitor, follow the instructions listed below. But the following procedure should only be performed by an experienced service technician.

### WARNING

It is recommended the game be left unplugged for at least one hour before removing the Video Monitor. This will probably discharge the CRT, but extreme caution is still necessary.

- (a) Make sure game is unplugged !!
- (b) Open the Rear Door Panel and remove the Front Screen.
- (c) Unplug all the harnesses and cables from the Video Monitor.
- (d) Standing at the front opening of the game, remove the four mounting bolts and flat washers. See Fig 14.
- (e) Carefully lift the Video Monitor and pull toward you.

### WARNING

Use extreme caution and do not touch electrical parts of the yoke area with your hands or with any metal object in your hands.

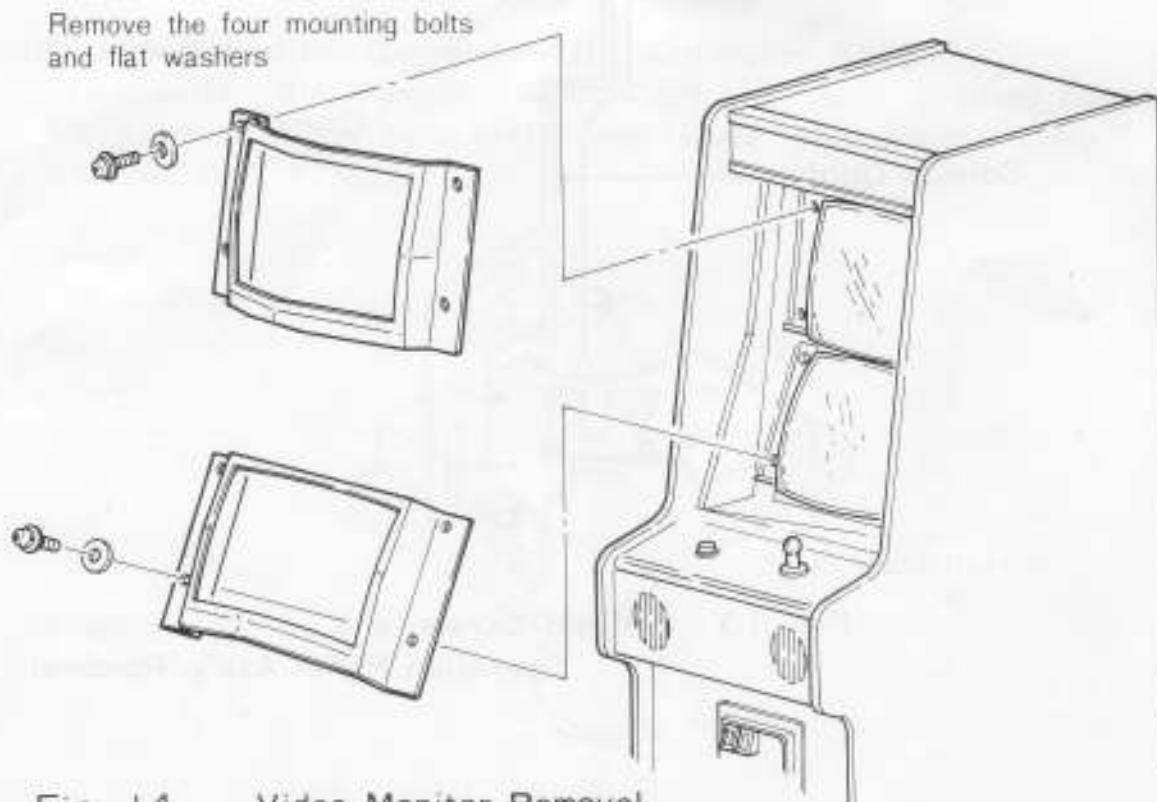

Fig. 14 Video Monitor Removal



## E. Game PCB Removal

- (a) Make sure the game is unplugged!!
- (b) Open the Rear Door Panel.
- (c) Remove the 56-pin edge connector from the right side of the 054-FCC PCB on the 054 Shield Cover.
- (d) Pull out 6 Fasteners located on perimeter of the 054 Shield Cover. See Fig. 15.
- (e) Remove the Game PCB from the 054 Shield Cage by carefully sliding it straight out of the wooden PCB retainers.
- (f) Pull out 2 Fasteners in the middle of the 054 Shield Cover. The Game PCB can now be removed. See Fig. 15.

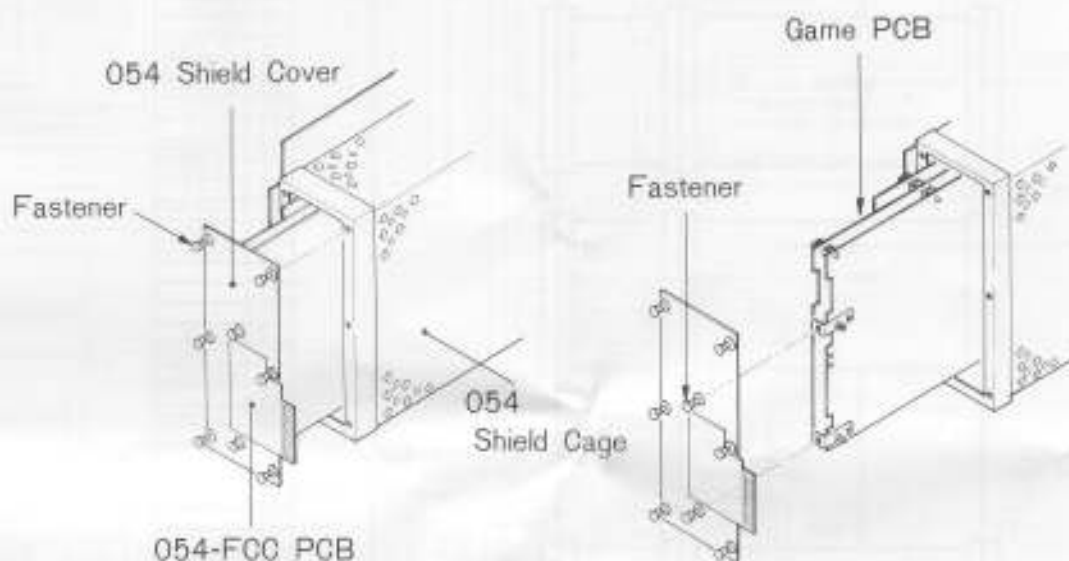

Fig. 15 Game PCB Removal

### WARNING

A reversed connector will damage your PCB!  
If the connectors don't slip on easily, don't force them!

## 5. Radio Frequency Interference (RFI)

In order to protect against the RFI radiated from this equipment, please comply with the following.

- (a) Do not use non-Nintendo parts!
- (b) Do not modify your game circuitry!
- (c) Do not modify the wiring harness and connections!
- (d) Connect this game only to a grounded 3-wire outlet.
- (e) After servicing the Game PCB, shut the 054 Shield Cover completely with the Fasteners. See Fig.15.

## 6. Wiring and Connection

Fig. 16 Wiring and Connection

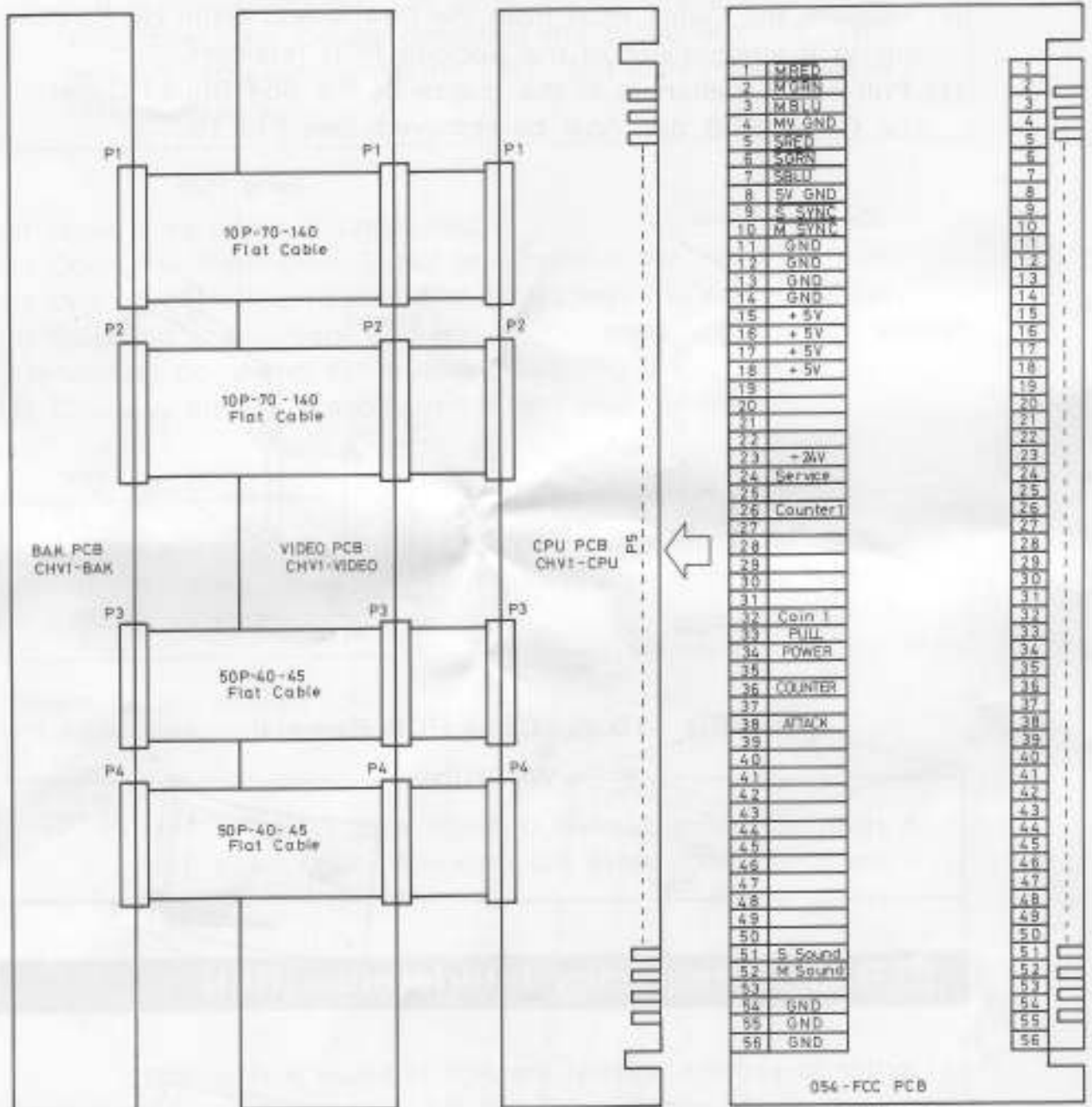

UP 56P 054 Edge  
Connecting  
Harness

1	MIBD	red
2	MIBN	brown
3	MIBU	orange
4	MV GND	red
5	SRED	yellow
6	SARN	brown
7	SBLU	orange
8	SV GND	blue
9	S SYNC	blue
10	M SYNC	blue
11	GND	
12	GND	
13	GND	
14	GND	
15	+ 5V	
16	- 5V	
17	- 5V	
18	- 5V	
19		
20		
21		
22		
23	- 24V	
24	Service	
25		
26	(Counter)	
27		
28		
29		
30		
31	Coin 2	
32	Coin 1	
33	PULL	azure/sky blue
34	POWER	yellow green
35		
36	COUNTER	brown
37	ATTACK	red
38		
39		
40		
41		
42		
43		
44		
45		
46		
47		
48		
49		
50		
51	S Sound	
52	M Sound	
53		
54	GND	green
55	GND	
56	GND	

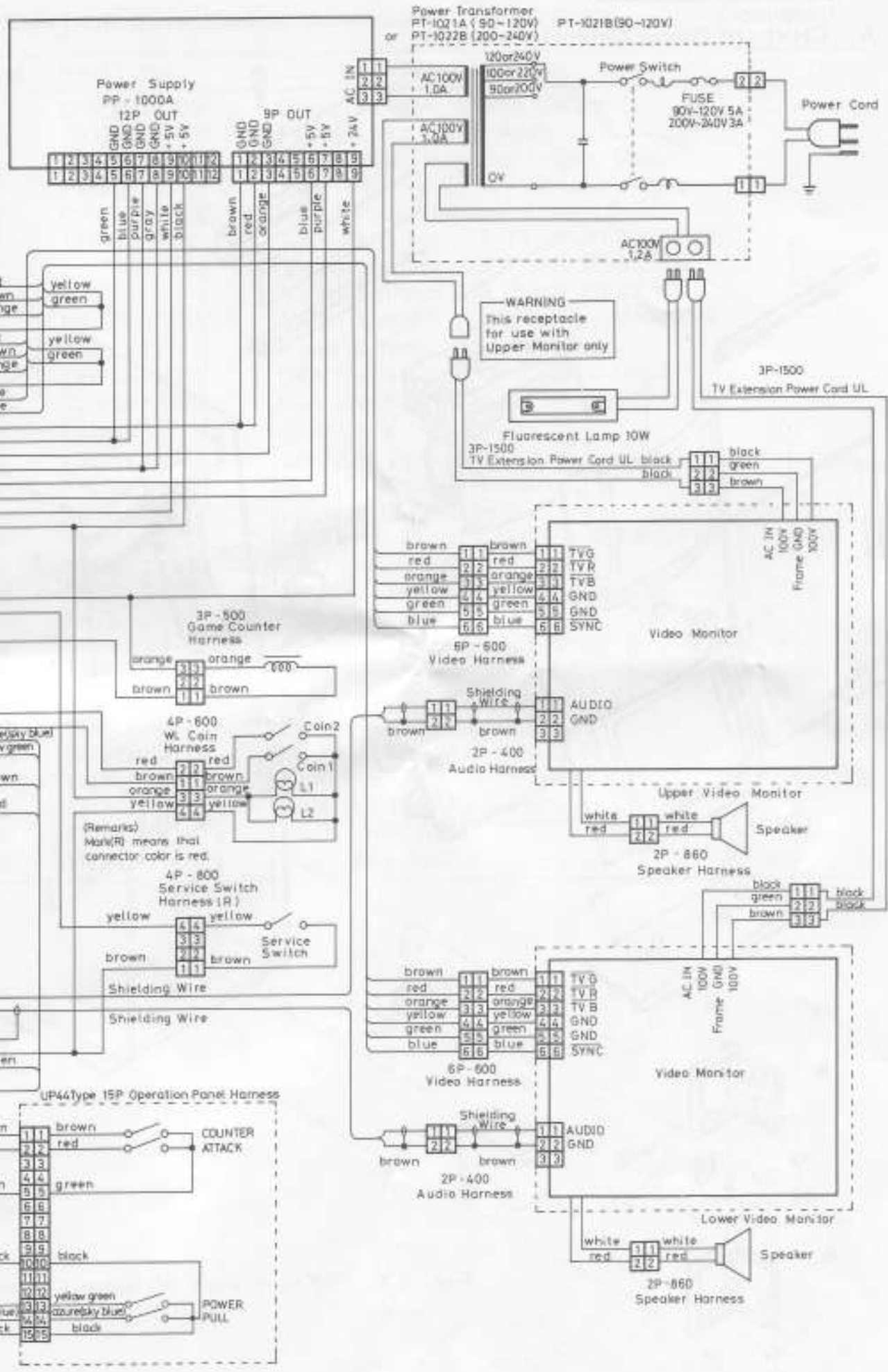

## 7. Parts Lists

### A. CHV1-UP Game Cabinet Assembly

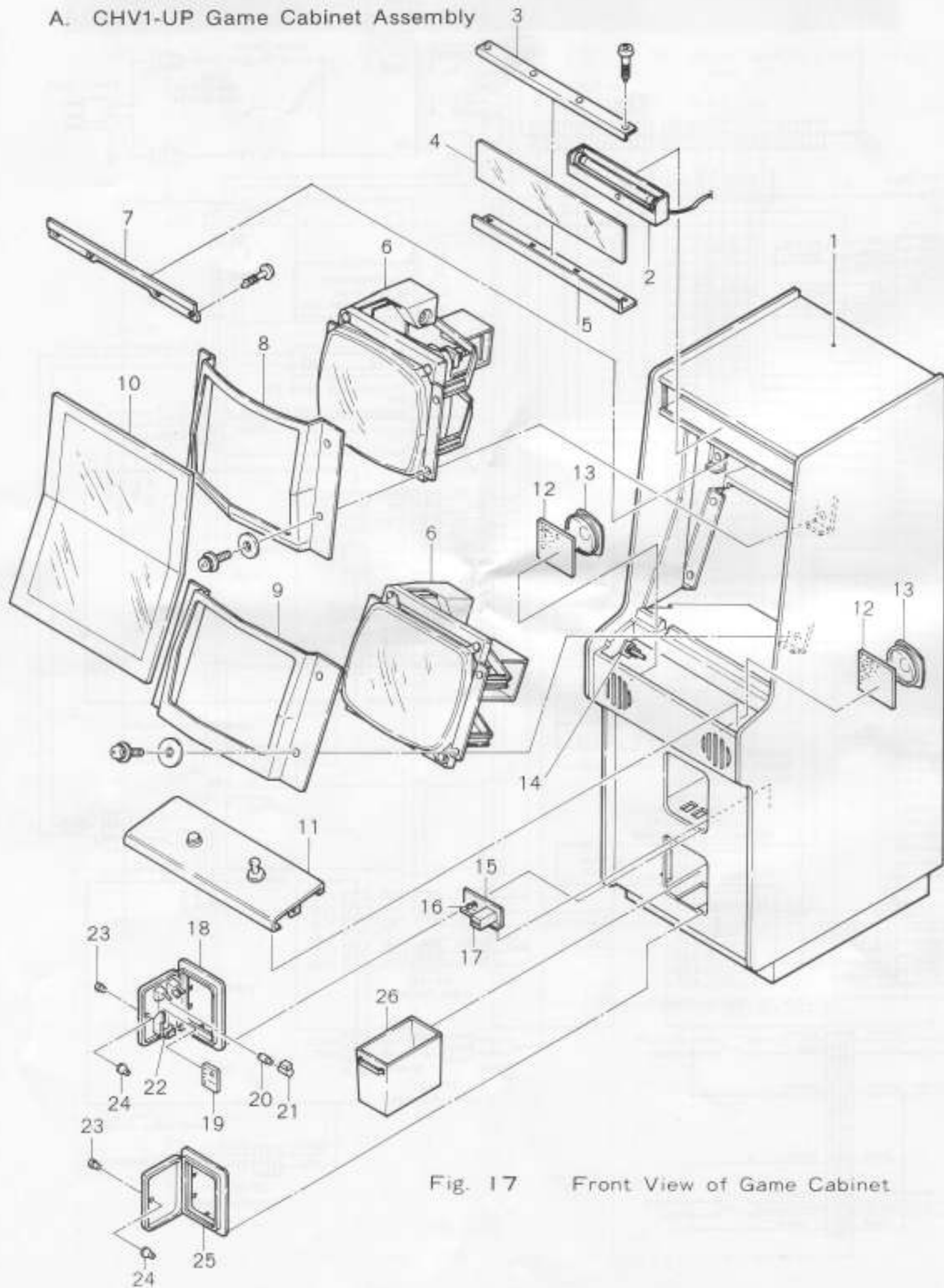

Fig. 17 Front View of Game Cabinet

## A. CHV1-UP Game Cabinet Assembly ; PARTS LIST

Continued

ITEM	PART No.	DESCRIPTION
1	CHPU-13-03	Body (Wooden Game Cabinet)
2	TKGU-01-29	Fluorescent Lamp Ass'y.
3	CHPU-11-19	Name Plate Retainer Upper 598L
4	CHVU-12-12	CHV Display Panel (Name Plate)
5	CHPU-11-11	Name Plate Retainer Lower 598L
6	TPPU-20-00	Video Monitor [32 Type] 20-EZV(R-C)
		Video Monitor [33 Type] 20-EZV(R-C)
		Video Monitor [35 Type] 20-Z2AW
6	MDSU-33-01	Video Monitor [Y51 Type] XM-2001N
7	CHPU-11-10	Front Screen Retainer 598L
8	CHPU-13-01	054 Black Cardboard Bezel Upper
9	CHPU-13-02	054 Black Cardboard Bezel Lower
10	CHPU-12-13	CHP-US Front Screen
11	CHVU-12-11	CHV-US Operation Panel (Panel Only)
12	TKGU-01-49	Speaker Grill (2 Required)
13	TKGU-01-43	Speaker (2 Required)
14	TKGU-01-31	Operation Panel Clamp A (2 Required)
15	TMAU-11-20	CS Plate 120W
16	TKGU-01-33	Service Switch (with Button)
17	TKGU-01-11	Game Counter
18	TMAU-14-17	Service Door ADD-S2: Order By Currency
19	TMAU-14-18	Coin Selector: Order By Currency
20	TMAU-34-17	Lamp BA-9S 6.3V 0.15A
21	TMAU-34-16	Lamp Socket BA-9S
22	TMAU-34-19	Micro-switch ADD D2MC-5F1
23	TMAU-14-12	Door Lock
24	TMAU-11-14	Cam B31R (2 Required)
25	TMAU-14-11	Cash Door ADD
26	TMAU-11-27	Cash Box ADD

A. CHV1-UP Game Cabinet Assembly

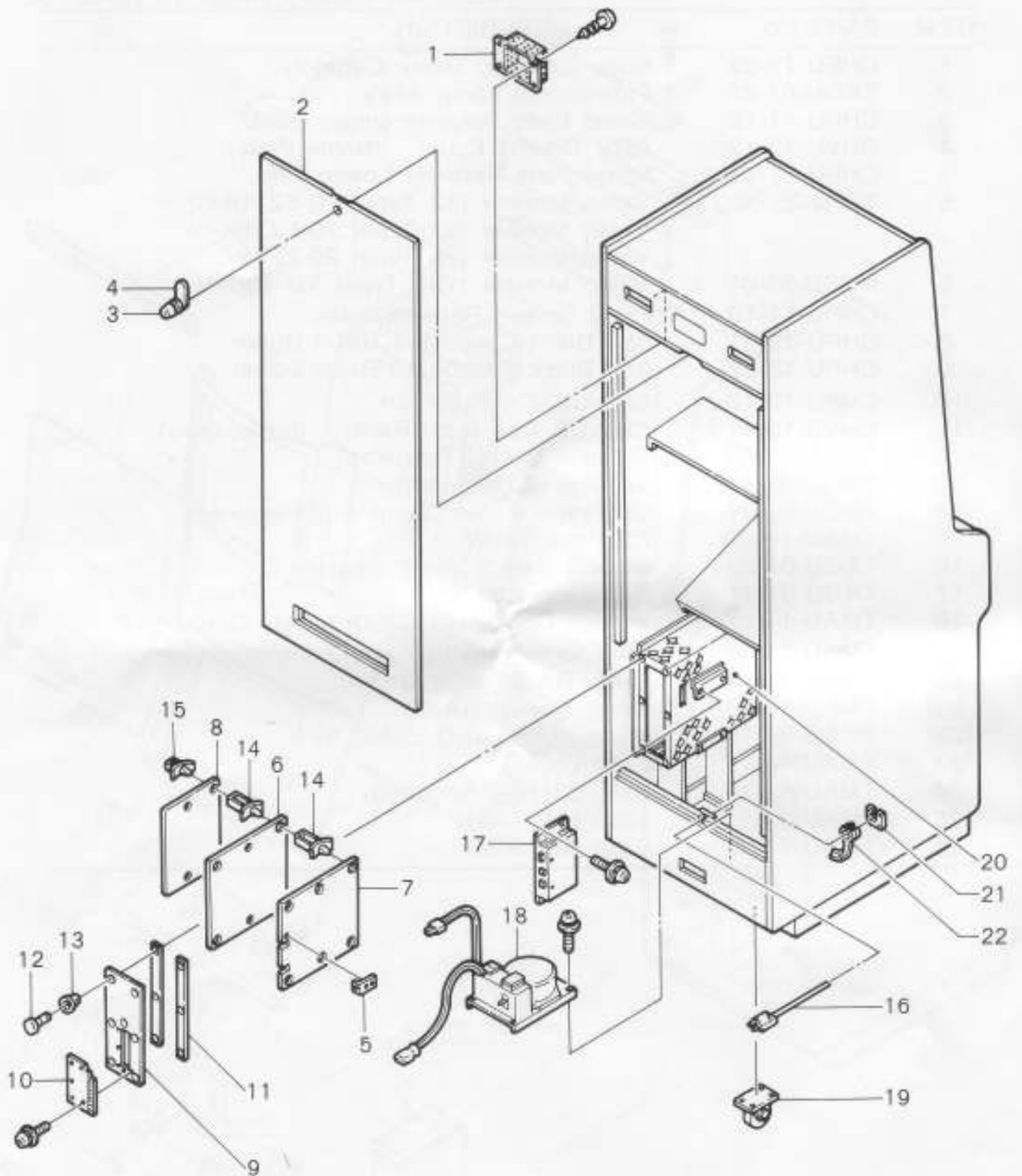

Fig. 18 Rear View of Game Cabinet

**A. CHV1-UP Game Cabinet Assembly : PARTS LIST**

ITEM	PART No.	DESCRIPTION
1	TKGU-01-61	Vent Grill (2 Required)
2	CHPU-13-15	Rear Door Panel
3	TMAU-14-14	Lock K6510
4	TMAU-11-15	Cam A
5	CHPU-11-18	PCB Stopper (2 Required)
6	CHVU-22-01	CHV1-VIDEO Complete PCB Assembly
7	CHVU-21-01	CHV1-CPU Complete PCB Assembly
8	CHVU-24-01	CHV1-BAK Complete PCB Assembly
9	CHPU-01-01-11	054 Shield Cover
10	CHPU-23-01	054-FCC Complete PCB Assembly
11	CHPU-11-17	054 Shield Spacer (2 Required)
12	CHPU-23-35	Nylatch Fastener (8 Required)
13	CHPU-23-34	Nylatch Grommet (8 Required)
14	CHPU-01-19	PCB Support CBSS-12N (9 Required)
15	CHPU-01-20	PCB Support CBSS-8N (5 Required)
16	TKGU-01-08	Power Cord: Order By Voltage & Plug Type
17	CHPU-88-01	PP-1000A Complete Power Supply Assembly
18	CHPU-08-01	PT-1021A Power Transformer (For 90~120V)
18	CHPU-18-01	PT-1021B Power Transformer (For 90~120V)
18	CHPU-18-02	PT-1022B Power Transformer (For 200~240V)
19	TKGU-01-30	Caster (2 Required)
20	CHPU-01-01-10	054 Shield Cage
21	TKGU-01-65	Strain Relief Bushing Plate
22	TKGU-01-10	Strain Relief Bushing

B. CHV1-UP Operation Panel Assembly

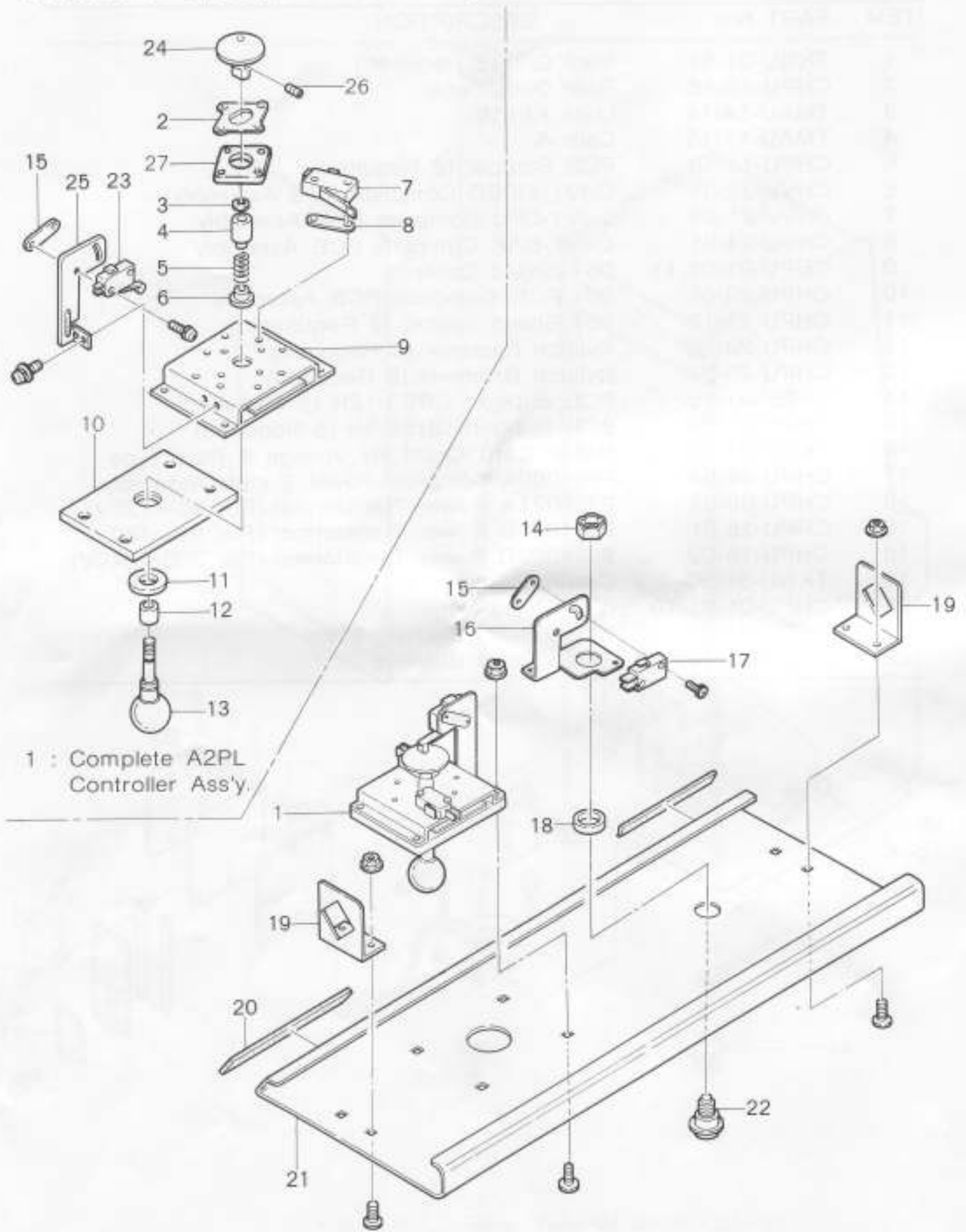

Fig. 19 Operation Panel Assembly



**B. CHV1-UP Operation Panel Assembly : PARTS LIST**

ITEM	PART No.	DESCRIPTION
1	CHVU-14-11	Complete A2PL Controller Ass'y.
2	TMAU-11-17	2 way Guide Plate
3	TKGU-23-23	E Ring 4
4	CHSU-11-12	A5 Switch Collar
5	TKGU-23-22	Lever Spring
6	TKGU-23-20	Spring Stopper
7	TKGU-23-13	Micro-switch VL12L (Bent) (2 Required)
8	TKGU-23-17	Switch Spacer (8 Required)
9	CHSU-11-11	A5 Bearing Bracket
10	TMAU-12-15	Lever Plate
11	TMAU-12-14	Control Knob Plate 28D
12	CHVU-12-13	Controller Knob Collar 23L
13	CHVU-11-11	A5 Knob with Shaft 101.5L
14	TKGU-23-34	Pal Nut
15	TKGU-23-26	Nut Plate (2 Required)
16	TKGU-23-12	Switch Button Bracket
17	TMAU-34-18	Micro-switch VL12L (Straight)
18	TMAU-12-18	Collar 34×28×7H
19	TMAU-11-19	Operation Panel Fastener B 38W (2 Required)
20	CHPU-12-17	Black Sponge 2×10×590L
21	CHVU-12-11	CHV-US Operation Panel
22	TKGU-23-32	Orange Button Ass'y.
23	TKGU-23-10	Micro-switch VL105L2
24	CHSU-11-15	Pull switch Button
25	CHSU-11-14	Pull switch Button Bracket
26	CHSU-51-11	Hexagon Socket Headless Set Screw
27	CHVU-12-14	Rubber Guide Plate

**C. CHV1-UP Wiring Harnesses**

PART No.	DESCRIPTION	See Fig. 16
CHPU-41-16	UP 56P 054 Edge Connecting Harness	
TPPU-93-02	2P-400 Audio Harness (400mm)	(2 Required)
TPPU-93-07	6P-600 Video Harness (600mm)	(2 Required)
TMAU-41-12	3P-500 Game Counter Harness (500mm)	
CHPU-41-13	4P-800 Service Switch Harness (800mm)	
TMAU-41-14	4P-600 WL Coin Harness (600mm)	
TKGU-13-17	2P Speaker Harness [2P-860] (860mm)	(2 Required)
CHPU-41-11	UP 44 Type 15P Operation Panel Harness	
CHPU-93-12	50P-40-45 Flat Cable	(2 Required)
CHPU-93-11	10P-70-140 Flat Cable	(2 Required)
CHVU-41-11	3P-1500 TV Extension Power Cord UL	(2 Required)

## D. CHV1-CPU PCB Assembly (For O1 and O2 versions) : PARTS LIST

PART No.	DESCRIPTION(Reference Designations and Locations)
CHVU-21-01	CHV1-CPU Complete PCB Assembly
CHVU-21-11	Z80A Microprocessor (6H)
CHVU-21-12	VLM5030 Speech Synthesizer (6M)
CHVU-21-13	RP2A03 Microprocessor (4H)
CHVU-21-15	2764 8K-Byte EP-ROM 250ns CHV1-C-4K (4K)
CHVU-21-16	2764 8K-Byte EP-ROM 300ns CHV1-C-8H (8H)
CHVU-21-17	2764 8K-Byte EP-ROM 300ns CHV1-C-8J (8J)
CHVU-21-18	2764 8K-Byte EP-ROM 300ns CHV1-C-8K (8K)
CHVU-21-19	2764 8K-Byte EP-ROM 300ns CHV1-C-8L (8L)
CHVU-21-20	27128 16K-Byte EP-ROM 300ns CHV1-C-6P (6P)
CHVU-21-21	27128 16K-Byte EP-ROM 300ns CHV1-C-8F (8F)
CHVU-21-22	HM6116AP-15 2K-Byte RAM 150ns (4L)
CHVU-21-23	TC5533P-A 4K-Byte RAM 150ns (8D)
CHVU-21-24	HM6264P-15 8K-Byte RAM 150ns (8C)
CHVU-21-25	TC5514AP-3 1Kx4-Bit C-MOS RAM 300ns (8M)
CHVU-21-26	74LS00 Quad 2-Input NAND (3B)
CHVU-21-27	74LS02 Quad 2-Input NOR (3A)
CHVU-21-28	74LS04 Hex Inverters (4B, 3C, 6D, 6E)
CHVU-21-29	74LS08 Quad 2-Input AND (5D)
CHVU-21-30	74LS14 Hex Schmitt Inverters (1C)
CHVU-21-31	74LS74A Dual "D" Flip-Flops (P, CL) (1D, 1F)
CHVU-21-32	74LS92 Divide-By-Twelve Counter (5L)
CHVU-21-33	74LS109A Dual J-K Flip-Flops (PLE, CL) (5F)
CHVU-21-34	74LS138 3 To 8 Decoder (2C, 2D, 7D)
CHVU-21-35	74LS139 Dual 2 To 4 Decoders (7E, 8A)
CHVU-21-36	74LS161A 4-Bit Binary Counters (2A, 5A, 5B, 6B, 7B)
CHVU-21-37	74LS194A 4-Bit Shift Registers (4A)
CHVU-21-38	74LS240 Octal Bus Inverters (TS) (1R, 2R, 5R, 6R)
CHVU-21-39	74LS245 Octal Bus Transceivers (TS) (7F)
CHVU-21-40	74LS259 8-Bit Addressable Latches (2B)
CHVU-21-41	74LS365 Hex Bus Drivers (5C, 6C, 7C)
CHVU-21-42	74LS367 Hex Bus Drivers (6F, 6K, 7K)
CHVU-21-43	74LS374 Octal "D" Flip-Flops (1A, 6A, 7A, 2H, 2J, 6L)
CHVU-21-44	74S04 Hex Inverters (5K)
CHVU-21-45	7437 Quad 2-Input NAND Buffers (5H)
CHVU-21-46	75471 Dual Peripheral AND Drivers (3S)
CHVU-21-47	74HC20 Dual 4-Input NAND (8N)
CHVU-21-48	PST518A Low Voltage Detector (3L)
CHVU-21-49	LM324 Quad Operational Amplifiers (2N)
CHVU-21-50	2SC1815 Silicon NPN Transistor (Q1~Q3)
CHVU-21-108	2SC2235 Silicon NPN Transistor (Q4)
CHVU-21-51	ES1F Diode (D1)
CHVU-21-52	1S5277B Diode (D2, D3)
CHVU-21-53	1S2076 Diode (D4~D6)

PART No.	DESCRIPTION(Reference Designations and Locations)	
CHVU-21-54	DAN401 Quad Cathode-Common Diode Array (DA1, DA2, DA3, DA4)	
CHVU-21-55	330 pf 50V $\pm 5\%$ Styrol Capacitor	(C36, C41)
CHVU-21-56	0.01 uf 50V $\pm 10\%$ Mylar Capacitor	(C34, C39)
CHVU-21-57	0.015 uf 50V $\pm 10\%$ Mylar Capacitor	(C35, C40)
CHVU-21-109	68 pf 50V Ceramic-Disc Capacitor	(C52)
CHVU-21-120	100pf 50V Ceramic-Disc Capacitor	(C10)
CHVU-21-58	180 pf 50V Ceramic-Disc Capacitor	(C30)
CHVU-21-59	220 pf 50V Ceramic-Disc Capacitor	(C44, C45)
CHVU-21-60	330 pf 50V Ceramic-Disc Capacitor	(C2, C46, C47, C51)
CHVU-21-61	1000 pf 50V Ceramic-Disc Capacitor	(C1)
CHVU-21-62	0.01 uf 50V Ceramic-Disc Capacitor	(C80 ~ C150)
CHVU-21-63	0.068 uf 50V Ceramic-Disc Capacitor	(C7, C8, C9)
CHVU-21-64	1 uf 16V Al Electrolytic Radial Cap.	(C3,C4,C31,C32,C37,C42)
CHVU-21-65	3.3 uf 16V Al Electrolytic Radial Cap.	(C5, C6)
CHVU-21-66	10 uf 16V Al Electrolytic Radial Cap.	(C33, C38)
CHVU-21-67	33 uf 16V Al Electrolytic Axial Cap.	(C43)
CHVU-21-68	220 uf 16V Al Electrolytic Axial Cap.	(C50)
CHVU-21-69	0 Ohm Shunt Lead	(R18, R19)
CHVU-21-70	10 Ohm 1/4W $\pm 5\%$ Resistor	(R6)
CHVU-21-71	51 Ohm 1/4W $\pm 5\%$ Resistor	(R14, R92)
CHVU-21-72	100 Ohm 1/4W $\pm 5\%$ Resistor	(R32, R33, R36, R37)
CHVU-21-73	110 Ohm 1/4W $\pm 5\%$ Resistor	(R3)
CHVU-21-74	180 Ohm 1/4W $\pm 5\%$ Resistor	(R61, R68)
CHVU-21-75	330 Ohm 1/4W $\pm 5\%$ Resistor	(R30, R31)
CHVU-21-76	820 Ohm 1/4W $\pm 5\%$ Resistor	(R1, R2, R64, R65)
CHVU-21-77	1K Ohm 1/4W $\pm 5\%$ Resistor	(R9, R62, R69, R80~R86, R88, R90)
CHVU-21-78	2.4K Ohm 1/4W $\pm 5\%$ Resistor	(R49)
CHVU-21-79	3.3K Ohm 1/4W $\pm 5\%$ Resistor	(R15, R16, R47)
CHVU-21-80	5.1K Ohm 1/4W $\pm 5\%$ Resistor	(R4, R7, R8, R17, R87)
CHVU-21-81	8.2K Ohm 1/4W $\pm 5\%$ Resistor	(R57)
CHVU-21-82	10K Ohm 1/4W $\pm 5\%$ Resistor	(R43, R51, R55)
CHVU-21-83	12K Ohm 1/4W $\pm 5\%$ Resistor	(R35, R39, R52)
CHVU-21-85	20K Ohm 1/4W $\pm 5\%$ Resistor	(R5, R34, R38)
CHVU-21-86	30K Ohm 1/4W $\pm 5\%$ Resistor	(R48)
CHVU-21-87	43K Ohm 1/4W $\pm 5\%$ Resistor	(R60, R67)
CHVU-21-88	75K Ohm 1/4W $\pm 5\%$ Resistor	(R44)
CHVU-21-89	100K Ohm 1/4W $\pm 5\%$ Resistor	(R45, R46, R53, R54, R56)
CHVU-21-110	110K Ohm 1/4W $\pm 5\%$ Resistor	(R59, R66)
CHVU-21-90	150K Ohm 1/4W $\pm 5\%$ Resistor	(R70, R71)
CHVU-21-91	200K Ohm 1/4W $\pm 5\%$ Resistor	(R10~R13)
CHVU-21-92	Hex 5.1K Ohm Series Resistor Array	(RM5)
CHVU-21-93	Octal 1K Ohm Series Resistor Array	(RM1~RM4)
CHVU-21-94	Quad 68 Ohm Parallel Resistor Array	(RM6~RM9)
CHVU-21-95	8 MHz Crystal	(X1)
CHVU-21-96	21.47727 MHz Crystal	(X2)

PART No.	DESCRIPTION(Reference Designations and Locations)
CHVU-21-97	4-Station, Single-Throw, DIP Bit Switch (SW1)
CHVU-21-98	8-Station, Single-Throw, DIP Bit Switch (SW2)
CHVU-21-111	24 Pin DIP IC Socket (S13)
CHVU-21-99	28 Pin DIP IC Socket (S4~S10)
CHVU-21-100	40 Pin DIP IC Socket (S1~S3)
CHVU-21-101	10 Pin Connector Receptacle (P1, P2)
CHVU-21-102	50 Pin Flat Cable Header (P3, P4)
CHVU-21-103	Battery Case TYPE33-3 (UM-3x3)
CHVU-21-104	Flat Head Screw M2.6x8
CHVU-21-105	Nut Plate M2.6-P30 (2 per assembly)
CHVU-21-106	Wire Tie T18L
CHVU-21-107	Dry Battery UM-3 ( "AA" Dry Cell) (3 per assembly)

There are different versions of the VIDEO P.C. Board.

CHV1-01-VIDEO : 01 version

CHV1-02-VIDEO : 02 version

When ordering parts, please give the part number and part name of each version parts list.

#### E. CHV1-VIDEO PCB Assembly (For 01 version) : PARTS LIST Continued

PART No.	DESCRIPTION (Reference Designations and Locations)
CHVU-22-01	CHV1-VIDEO Complete PCB Assembly
CHVU-22-15	2764 8K-Byte EP-ROM 450ns CHV1-V-6N (6N)
CHVU-22-16	2764 8K-Byte EP-ROM 450ns CHV1-V-8N (8N)
CHVU-22-17	2764 8K-Byte EP-ROM 450ns CHV1-V-6P (6P)
CHVU-22-18	2764 8K-Byte EP-ROM 450ns CHV1-V-8P (8P)
CHVU-22-19	27128 16K-Byte EP-ROM 300ns CHV1-V-2R (2R)
CHVU-22-20	27128 16K-Byte EP-ROM 300ns CHV1-V-3R (3R)
CHVU-22-21	27128 16K-Byte EP-ROM 300ns CHV1-V-4R (4R)
CHVU-22-22	27128 16K-Byte EP-ROM 300ns CHV1-V-2T (2T)
CHVU-22-23	27128 16K-Byte EP-ROM 300ns CHV1-V-3T (3T)
CHVU-22-24	27128 16K-Byte EP-ROM 300ns CHV1-V-4T (4T)
CHVU-22-25	27128 16K-Byte EP-ROM 300ns CHV1-V-2U (2U)
CHVU-22-26	27128 16K-Byte EP-ROM 300ns CHV1-V-3U (3U)
CHVU-22-27	27128 16K-Byte EP-ROM 300ns CHV1-V-4U (4U)
CHVU-22-28	27128 16K-Byte EP-ROM 300ns CHV1-V-2V (2V)
CHVU-22-29	27128 16K-Byte EP-ROM 300ns CHV1-V-3V (3V)
CHVU-22-30	N82S129N 256x4-Bit Bipolar ROM CHV1-V-2D (2D)
CHVU-22-31	HM6116ASP-15 2K-Byte RAM 150ns (8H, 2N)

PART No.	DESCRIPTION (Reference Designations and Locations)
CHVU-21-26	74LS00 Quad 2-Input NAND (1E, 6S, 5L)
CHVU-21-28	74LS04 Hex Inverters (6C, 4D, 4E, 6E, 1J, 6T)
CHVU-22-32	74LS10 Triple 3-Input NAND (6U)
CHVU-22-33	74LS11 Triple 3-Input AND (8D, 6V)
CHVU-22-34	74LS20 Dual 4-Input NAND (7V)
CHVU-22-35	74LS21 Dual 4-Input AND (1K)
CHVU-21-31	74LS74A Dual "D" Flip-Flops (P, CL) (3D, 6R, 7S, 7T, 7U)
CHVU-22-36	74LS86 Quad 2-Input Exclusive OR (7D, 1H, 5P, 1S)
CHVU-21-34	74LS138 3 To 8 Decoder (5B, 5E, 1R)
CHVU-21-35	74LS139 Dual 2 To 4 Decoders (5F, 6J)
CHVU-22-37	74LS151 8 To 1 Data Selector (1U, 1W, 4W)
CHVU-22-38	74LS153 Dual 4 To 1 Data Selectors (5C, 5D)
CHVU-22-39	74LS157 Quad 2 To 1 Data Selectors (4P, 7F, 8F, 6H, 4N, 5N)
CHVU-22-40	74LS158 Quad 2 To 1 Data Selectors (7R)
CHVU-21-36	74LS161A 4-Bit Binary Counters (2A, 7C, 8C, 6D, 2E, 3E, 7E, 8E, 6F, 3M, 4M, 5M, 8T, 8U)
CHVU-22-41	74LS164 8-Bit Shift Registers (5J, 5K, 2L, 2M)
CHVU-22-42	74LS174 Hex "D" Flip-Flops (3L, 4L)
CHVU-22-43	74LS175 Quad "D" Flip-Flops (CL) (2C)
CHVU-22-44	74LS244 Octal Buffers & Line Drivers (TS) (3N, 3P, 5H)
CHVU-22-45	74LS273 Octal "D" Flip-Flops (CL) (7H, 8J, 1N, 1P, 2P)
CHVU-22-46	74LS283 4-Bit Full Adder (2K, 3K, 4K)
CHVU-22-47	74LS299 8-Bit Shift/Storage Registers (8R, 8S)
CHVU-21-42	74LS367 Hex Bus Drivers (2B, 5W)
CHVU-22-48	74LS373 Octal "D" Transparent Latches (3A, 3B, 7B, 8B, 3C)
CHVU-21-43	74LS374 Octal "D" Flip-Flops (8V)
CHVU-22-49	74LS375 4-Bit Bistable Latches (4A, 5A, 4B, 6B, 4C)
CHVU-22-50	74LS377 Octal "D" Flip-Flops (7J, 1T, 1V, 4V)
CHVU-21-44	74S04 Hex Inverters (1B)
CHVU-22-51	74F04 Hex Inverters (1C)
CHVU-22-52	74F74 Dual "D" Flip-Flops (P, CL) (1D, 4H)
CHVU-22-53	74F161 4-Bit Binary Counters (1F, 2F, 3F, 4F)
CHVU-22-54	74F174 Hex "D" Flip-Flops (2H, 3H)
CHVU-22-55	74F283 4-Bit Full Adder (2J, 3J, 4J)
CHVU-21-51	ES1F Diode (D1)
CHVU-21-120	100 pf 50V Ceramic-Disc Capacitor (C10, C11, C12, C13, C141)
CHVU-21-58	180 pf 50V Ceramic-Disc Capacitor (C1)
CHVU-21-60	330 pf 50V Ceramic-Disc Capacitor (C2, C3, C4, C15, C17, C140)
CHVU-21-62	0.01 uf 50V Ceramic-Disc Capacitor (C20~C138)
CHVU-21-68	220 uf 16V Al Electrolytic Axial Cap. (C5)

PART No.	DESCRIPTION (Reference Designations and Locations)
CHVU-21-75	330 Ohm 1/4W $\pm 5\%$ Resistor (R1, R2)
CHVU-21-77	1K Ohm 1/4W $\pm 5\%$ Resistor (R20~R31)
CHVU-21-79	3.3K Ohm 1/4W $\pm 5\%$ Resistor (R3, R4)
CHVU-21-93	Octal 1K Ohm Series Resistor Array (RM1)
CHVU-22-57	20.160MHz Crystal (X1)
CHVU-22-58	16 Pin DIP IC Socket (S21)
CHVU-21-99	28 Pin DIP IC Socket (S1~S11, S13~S20)
CHVU-21-101	10 Pin Connector Receptacle (P1, P2)
CHVU-21-102	50 Pin Flat Cable Header (P3, P4)

#### F. CHV1-VIDEO PCB Assembly (For O2 version) : PARTS LIST Continued

PART No.	DESCRIPTION (Reference Designations and Locations)
CHVU-22-01	CHV1-VIDEO Complete PCB Assembly
CHVU-22-59	2564 8K-Byte EP-ROM 450ns CHV1-V-6N (6N)
CHVU-22-60	2564 8K-Byte EP-ROM 450ns CHV1-V-8N (8N)
CHVU-22-61	2564 8K-Byte EP-ROM 450ns CHV1-V-6P (6P)
CHVU-22-62	2564 8K-Byte EP-ROM 450ns CHV1-V-8P (8P)
CHVU-22-19	27128 16K-Byte EP-ROM 300ns CHV1-V-2R (2R)
CHVU-22-20	27128 16K-Byte EP-ROM 300ns CHV1-V-3R (3R)
CHVU-22-21	27128 16K-Byte EP-ROM 300ns CHV1-V-4R (4R)
CHVU-22-22	27128 16K-Byte EP-ROM 300ns CHV1-V-2T (2T)
CHVU-22-23	27128 16K-Byte EP-ROM 300ns CHV1-V-3T (3T)
CHVU-22-24	27128 16K-Byte EP-ROM 300ns CHV1-V-4T (4T)
CHVU-22-25	27128 16K-Byte EP-ROM 300ns CHV1-V-2U (2U)
CHVU-22-26	27128 16K-Byte EP-ROM 300ns CHV1-V-3U (3U)
CHVU-22-27	27128 16K-Byte EP-ROM 300ns CHV1-V-4U (4U)
CHVU-22-28	27128 16K-Byte EP-ROM 300ns CHV1-V-2V (2V)
CHVU-22-29	27128 16K-Byte EP-ROM 300ns CHV1-V-3V (3V)
CHVU-22-30	N82S129N 256x4-Bit Bipolar ROM CHV1-V-2D (2D)
CHVU-22-31	HM6116ASP-15 2K-Byte RAM 150ns (8H, 2N)
CHVU-21-26	74LS00 Quad 2-Input NAND (1E, 6S, 5L)
CHVU-21-28	74LS04 Hex Inverters (6C, 4D, 4E, 6E, 1J, 6T)
CHVU-22-32	74LS10 Triple 3-Input NAND (6U)
CHVU-22-33	74LS11 Triple 3-Input AND (8D, 6V)
CHVU-22-34	74LS20 Dual 4-Input NAND (7V)
CHVU-22-35	74LS21 Dual 4-Input AND (1K)
CHVU-21-31	74LS74A Dual "D" Flip-Flops (P, CL) (3D, 6R, 7S, 7T, 7U)

PART No.	DESCRIPTION (Reference Designations and Locations)
CHVU-22-36	74LS86 Quad 2-Input Exclusive OR (7D, 1H, 5P, 1S)
CHVU-21-34	74LS138 3 To 8 Decoder (5B, 5E, 1R)
CHVU-21-35	74LS139 Dual 2 To 4 Decoders (5F, 6J)
CHVU-22-37	74LS151 8 To 1 Data Selector (1U, 1W, 4W)
CHVU-22-38	74LS153 Dual 4 To 1 Data Selectors (5C, 5D)
CHVU-22-39	74LS157 Quad 2 To 1 Data Selectors (4P, 7F, 8F, 6H, 4N, 5N, 7R)
CHVU-21-36	74LS161A 4-Bit Binary Counters (2A, 7C, 8C, 6D, 2E, 3E, 7E, 8E, 6F, 3M, 4M, 5M, 8T, 8U)
CHVU-22-41	74LS164 8-Bit Shift Registers (5J, 5K, 2L, 2M)
CHVU-22-42	74LS174 Hex "D" Flip-Flops (3L, 4L)
CHVU-22-43	74LS175 Quad "D" Flip-Flops (CL) (2C)
CHVU-22-44	74LS244 Octal Buffers & Line Drivers (TS) (3N, 3P, 5H)
CHVU-22-45	74LS273 Octal "D" Flip-Flops (CL) (7H, 8J, 1N, 1P, 2P)
CHVU-22-46	74LS283 4-Bit Full Adder (2K, 3K, 4K)
CHVU-22-47	74LS299 8-Bit Shift/Storage Registers (8R, 8S)
CHVU-21-42	74LS367 Hex Bus Drivers (2B, 5W)
CHVU-22-48	74LS373 Octal "D" Transparent Latches (3A, 3B, 7B, 8B, 3C)
CHVU-21-43	74LS374 Octal "D" Flip-Flops (8V)
CHVU-22-49	74LS375 4-Bit Bistable Latches (4A, 5A, 4B, 6B, 4C)
CHVU-22-50	74LS377 Octal "D" Flip-Flops (7J, 1T, 1V, 4V)
CHVU-21-44	74S04 Hex Inverters (1B)
CHVU-22-51	74F04 Hex Inverters (1C)
CHVU-22-52	74F74 Dual "D" Flip-Flops (P, CL) (1D, 4H)
CHVU-22-53	74F161 4-Bit Binary Counters (1F, 2F, 3F, 4F)
CHVU-22-54	74F174 Hex "D" Flip-Flops (2H, 3H)
CHVU-22-55	74F283 4-Bit Full Adder (2J, 3J, 4J)
CHVU-21-51	ES1F Diode (D1)
CHVU-21-120	100 pf 50V Ceramic-Disc Capacitor (C10,C11,C12,C13,C14)
CHVU-21-58	180 pf 50V Ceramic-Disc Capacitor (C1)
CHVU-21-60	330 pf 50V Ceramic-Disc Capacitor (C2,C3,C4,C15,C17,C140)
CHVU-21-62	0.01 uf 50V Ceramic-Disc Capacitor (C20~C138)
CHVU-21-68	220 uf 16V Al Electrolytic Axial Cap. (C5)
CHVU-21-75	330 Ohm 1/4W $\pm 5\%$ Resistor (R1, R2)
CHVU-21-77	1K Ohm 1/4W $\pm 5\%$ Resistor (R20~R31)
CHVU-21-79	3.3K Ohm 1/4W $\pm 5\%$ Resistor (R3, R4)
CHVU-21-93	Octal 1K Ohm Series Resistor Array (RM1)
CHVU-22-57	20.160MHz Crystal (X1)
CHVU-22-58	16 Pin DIP IC Socket (S21)
CHVU-21-99	28 Pin DIP IC Socket (S1~S11, S13~S20)
CHVU-21-101	10 Pin Connector Receptacle (P1, P2)
CHVU-21-102	50 Pin Flat Cable Header (P3, P4)

## G. CHV1 -BAK PCB Assembly : PARTS LIST

Continued

PART No.	DESCRIPTION (Reference Designation and Locations)
CHVU-24-01	CHV1-BAK Complete PCB Assembly
CHVU-24-11	2764 8K-Byte EP-ROM 300ns CHV1-B-2K (2K)
CHVU-24-12	27128 16K-Byte EP-ROM 300ns CHV1-B-2D (2D)
CHVU-24-13	27128 16K-Byte EP-ROM 300ns CHV1-B-2E (2E)
CHVU-24-14	27128 16K-Byte EP-ROM 300ns CHV1-B-2L (2L)
CHVU-24-15	27128 16K-Byte EP-ROM 300ns CHV1-B-2M (2M)
CHVU-24-16	N82S131N 512x4-Bit Bipolar ROM CHV1-B-4B (4B)
CHVU-24-17	N82S131N 512x4-Bit Bipolar ROM CHV1-B-4C (4C)
CHVU-24-18	N82S131N 512x4-Bit Bipolar ROM CHV1-B-4D (4D)
CHVU-24-19	N82S131N 512x4-Bit Bipolar ROM CHV1-B-7B (7B)
CHVU-24-20	N82S131N 512x4-Bit Bipolar ROM CHV1-B-7C (7C)
CHVU-24-21	N82S131N 512x4-Bit Bipolar ROM CHV1-B-7D (7D)
CHVU-24-22	N82S129N 256x4-Bit Bipolar ROM CHV1-B-3C (3C)
CHVU-22-31	HM6116ASP-15 2K-Byte RAM 150ns (5F, 5H, 5L)
CHVU-21-26	74LS00 Quad 2-Input NAND (4H, 4K)
CHVU-21-28	74LS04 Hex Inverters (4J, 4L, 4M)
CHVU-22-38	74LS153 Dual 4 To 1 Data Selectors (1A,2A,2B,3B,6H,6L)
CHVU-22-39	74LS157 Quad 2 To 1 Data Selectors (1B,1H,1J,2J,3A,4A)
CHVU-21-36	74LS161A 4-Bit Binary Counters (4F,6F,5M,6M)
CHVU-22-42	74LS174 Hex "D" Flip-Flops (2H)
CHVU-22-44	74LS244 Octal Buffers & Line Drivers (TS) (3H,3J,3K)
CHVU-24-23	74LS257 Quad 2 To 1 Data Selectors(TS)(7F,7H,7J,7K,7L,7M)
CHVU-22-45	74LS273 Octal "D" Flip-Flops (CL) (1N)
CHVU-22-47	74LS299 8-Bit Shift/Storage Registers (1C,1F,1K,1L,1M,2C,2F)
CHVU-21-42	74LS367 Hex Bus Drivers (4N, 5J, 6J, 5K, 6K)
CHVU-22-50	74LS377 Octal "D" Flip-Flops (1D, 1E, 3D, 3E, 3F, 3L, 3M)
CHVU-21-50	2SC1815 Silicon NPN Transistor (Q1, Q3, Q5, Q7, Q8, Q10, Q12, Q14)
CHVU-24-24	2SA1015 Silicon PNP Transistor (Q2,Q4,Q6,Q9,Q11,Q13)
CHVU-21-51	ES1F Diode (D1)
CHVU-21-120	100 pf 50V Ceramic-Disc Capacitor (C6, C7)
CHVU-21-59	220 pf 50V Ceramic-Disc Capacitor (C5)
CHVU-21-62	0.01 uf 50V Ceramic-Disc Capacitor (C20~C97)
CHVU-21-67	33 uf 16V Al Electrolytic Axial Cap. (C2~C4)
CHVU-21-68	220 uf 16V Al Electrolytic Axial Cap. (C1)



PART No.	DESCRIPTION (Reference Designations and Locations)
CHVU-21-71	51 Ohm 1/4W $\pm 5\%$ Resistor (R4, R8, R12, R17, R44, R48, R52, R55)
CHVU-21-72	100 Ohm 1/4W $\pm 5\%$ Resistor (R1, R5, R9, R15, R41, R45, R49, R53)
CHVU-24-25	240 Ohm 1/4W $\pm 5\%$ Resistor (R23, R28, R33, R63, R68, R73)
CHVU-21-75	330 Ohm 1/4W $\pm 5\%$ Resistor (R2, R3, R6, R7, R10, R11, R16, R42, R43, R46, R47, R50, R51, R54)
CHVU-24-26	470 Ohm 1/4W $\pm 5\%$ Resistor (R22, R24, R27, R29, R32, R34, R62, R64, R67, R69, R72, R74)
CHVU-21-77	1K Ohm 1/4W $\pm 5\%$ Resistor (R21, R26, R31, R61, R66, R71, R80~R89)
CHVU-24-27	2K Ohm 1/4W $\pm 5\%$ Resistor (R13, R20, R25, R30, R60, R65, R70)
CHVU-24-28	7.5K Ohm 1/4W $\pm 5\%$ Resistor (R14)
CHVU-21-93	Octal 1K Ohm Series Resistor Array (RM1)
CHVU-22-58	16 Pin DIP IC Socket (S6~S11)
CHVU-21-99	28 Pin DIP IC Socket (S1~S5)
CHVU-21-101	10 Pin Connector Receptacle (P1, P2)
CHVU-21-102	50 Pin Flat Cable Header (P3, P4)

#### H. 054-FCC PCB Assembly : PARTS LIST

PART No.	DESCRIPTION (Reference Designations)
CHPU-23-01	054-FCC Complete PCB Assembly
CHPU-23-11	252-28-50-168 56P Edge Connector
CHPU-23-12	330 pf 50V Ceramic-Disc Capacitor (C1~C30)
CHPU-23-13	Ferrite Beads BL 02RN2-R62 (FC1~FC30)

PART No.	DESCRIPTION (Reference Designations)
CHPU-88-01	PP-1000A Complete Power Supply Assembly
CHPU-88-02	3D-0163 Complete Power Supply PCB Assembly
CHPU-88-11	3D-3000 Hybrid IC (IC1)
CHPU-88-12	uPC78M24 3-Terminal Regulator (IC2)
CHPU-88-13	TL431CLP Adjustable Shunt Regulator (IC3)
CHPU-88-14	TLP541G Photo Coupler (PC1)
CHPU-88-15	PC614 Photo Coupler (PC2)
CHPU-88-16	RB404/S4VB40 Diode (D1)
CHPU-88-17	C25P04Q/20CS04M Diode (D12)
CHPU-88-18	30DF2 Diode (D11)
CHPU-88-19	1S1835/10DF6 Diode (D6, D7, D10, D14)
CHPU-88-20	1S954 Diode (D3)
CHPU-88-21	RD5. 1EB3 Zener Diode (ZD1)
CHPU-88-22	5P2M Thyristor (Q1)
CHPU-88-23	2SC2562 Silicon NPN Transistor (Q2)
CHPU-88-24	2SC2749 Silicon NPN Transistor (Q3)
CHPU-88-25	0.01 uf 50V Mylar Capacitor (C6, C9, C27)
CHPU-88-26	0.1 uf 50V Mylar Capacitor (C13)
CHPU-88-27	1000 pf 50V Mylar Capacitor (C12)
CHPU-88-28	0.047 uf 630V Metallized Film Cap. (C1, C4)
CHPU-88-29	0.22 uf 250V Metallized Film Cap. (C10, C28, C29)
CHPU-88-30	2200 pf 2KV Ceramic-Disc Capacitor (C2,C3,C11,C15,C18)
CHPU-88-31	4.7 uf 50V Al Electrolytic Cap. (C7)
CHPU-88-32	47 uf 35V Al Electrolytic Cap. (C8, C17)
CHPU-88-33	330 uf 200V Al Electrolytic Cap. (C5)
CHPU-88-34	1000 uf 50V Al Electrolytic Cap. (C16)
CHPU-88-35	3300 uf 10V Al Electrolytic Cap. (C19~C26)
CHPU-88-36	100 Ohm 1/4W $\pm 5\%$ Carbon Resistor (R9,R11,R12,R23,R24)
CHPU-88-37	1K Ohm 1/4W $\pm 5\%$ Carbon Resistor (R4, R6, R15)
CHPU-88-38	1.5K Ohm 1/4W $\pm 5\%$ Carbon Resistor (R25)
CHPU-88-39	2.4K Ohm 1/4W $\pm 5\%$ Carbon Resistor (R26)
CHPU-88-40	10K Ohm 1/4W $\pm 5\%$ Carbon Resistor (R7)
CHPU-88-41	24K Ohm 1/4W $\pm 5\%$ Carbon Resistor (R17)
CHPU-88-42	30K Ohm 1/4W $\pm 5\%$ Carbon Resistor (R8)
CHPU-88-43	5.1 Ohm 1/2W $\pm 5\%$ Carbon Resistor (R19, R21)
CHPU-88-44	100 Ohm 1/2W $\pm 5\%$ Carbon Resistor (R5)
CHPU-88-45	100K Ohm 1/2W $\pm 5\%$ Carbon Resistor (R3, R14)
CHPU-88-46	5.1 Ohm 5W $\pm 5\%$ Cement Resistor (R1)
CHPU-88-47	20 Ohm 5W $\pm 5\%$ Cement Resistor (R22)
CHPU-88-48	30 Ohm 5W $\pm 5\%$ Cement Resistor (R10)
CHPU-88-49	100 Ohm 5W $\pm 5\%$ Cement Resistor (R16)
CHPU-88-50	510 Ohm 5W $\pm 5\%$ Cement Resistor (R20)
CHPU-88-51	2K Ohm Vertical Cermet Trimpot (VR2)
CHPU-88-52	50K Ohm Vertical Cermet Trimpot (VR1)
CHPU-88-53	EI-40 Type 3D-0163 Switching Transformer (TR)

PART No.	DESCRIPTION (Reference Designations)	
CHPU-88-54	SC2A Choke Coil	(L1)
CHPU-88-55	SF-C27-00105-01 Choke Coil	(L2)
CHPU-88-56	3A FGMB NR Type Fuse	
CHPU-88-57	OG751-0062 Fuse Holder	(2 per assembly)
CHPU-88-58	Heat Sink Clip	(3 per assembly)
CHPU-88-59	Thermally Conductive Rubber	
CHPU-88-60	2-Pin AC Input Connector Receptacle on PCB	
CHPU-88-61	6-Pin DC Output Connector Receptacle on PCB	
CHPU-88-62	7-Pin DC Output Connector Receptacle on PCB	
CHPU-88-65	3D-0163-32 Type Heat Sink	
CHPU-88-63	3D-0163-30 Type Metal Frame	
CHPU-88-64	3D-0163-31 Type Metal Cover	
CHPU-88-66	3-Pin AC Input Connector Ass'y. on Metal Frame	
CHPU-88-67	9-Pin DC Output Connector Ass'y. on Metal Frame	
CHPU-88-68	12-Pin DC Output Connector Ass'y. on Metal Frame	
CHPU-88-69	Metal PCB Retainer	(4 per assembly)

#### J. CHV1-UP Fuses

PART No.	DESCRIPTION(Reference Designations)		
TKGU-11-08	Main Fuse U.S.	5A 125V	
CHVU-63-11	Main Fuse Europe	3A 250V	
CHPU-88-56	Power Supply Fuse	3A 125V(Midget)	
TKGU-11-12	Video Monitor Fuse 20-EZV(R-C), 20-Z2AW	4A 125V(Slow Blow)	(F302)
TKGU-11-13	Video Monitor Fuse 20-EZV(R-C), 20-Z2AW	0.3A 125V(Midget)	(F301)
MDST-63-12	Video Monitor Fuse XM-2001N	2.5A 125V(Slow Blow)	(F702)
MDST-63-13	Video Monitor Fuse XM-2001N	3A 125V(Slow Blow)	(F701)

