



User Manual

Caution

In order to ensure that this product may be used safely, please make sure that this manual is read and fully understood in advance. Following this, please keep the manual in a readily-accessible location for easy reference.



Introduction

Thank you for purchasing THE KING OF FIGHTERS NEOWAVE™.

This manual has been written for managers and administrators of this product, and in addition to details regarding administration, maintenance, and inspection, it also covers instructions on how the product may be used safely. Please ensure that only persons having read and fully understood this manual be allowed to operate, manager, or maintain this product. Also, this manual should be kept in a secure place so that it may easily be referred to when necessary during routine operation.

Please note that the content of this manual is subject to change without notice in accordance with improvements to the product.

Please read this manual before use.

In order to ensure that this product may be used safely, please ensure that this manual is read and fully understood in advance. Please contact one of the following if this manual is misplaced, if inaccuracies are noticed, or if you have any other comments or suggestions.

Sammy Corporation

2-23-2, Higashi-Ikebukuro, Toshima-ku, Tokyo, Japan 170-8436

Phone: +81-3-5950-3805, Facsimile: +81-3-5950-3761

Sammy USA Corporation

901 Cambridge Drive, Elk Grove Village, IL 60007-2434, U.S.A.

Phone: (847) 364-9787, Facsimile: (847) 364-9831

Sammy Europe Limited

First Floor, Healthaid House, Marlborough Hill, Harrow, Middlesex, HA1 1UD, U.K.

Phone: +44-20-8427-8427, Facsimile: +44-20-8861-1209

Addresses and contact numbers correct at time of going to press in July 2004.

1. Safety Precautions

CAUTION

In order to avoid breakdown, please ensure that the power is turned off before insertion or removal of a ROM cartridge.

2. Accessories

User Manual (this document):	1
Instruction Sheet B:	2
Instruction Sticker D:	2
Instruction Sticker E:	2
Instruction Sticker E':	2

3. Inserting and Removing ROM Cartridges

Note

Please ensure that the power is turned off before insertion or removal of a ROM cartridge.

Removal

Grip the ROM cartridge by its two tabs and lift out of the cartridge slot.

Insertion

Check that the ROM cartridge is correctly oriented then insert into the cartridge slot. Press down Point 1 until a clicking sound heard.

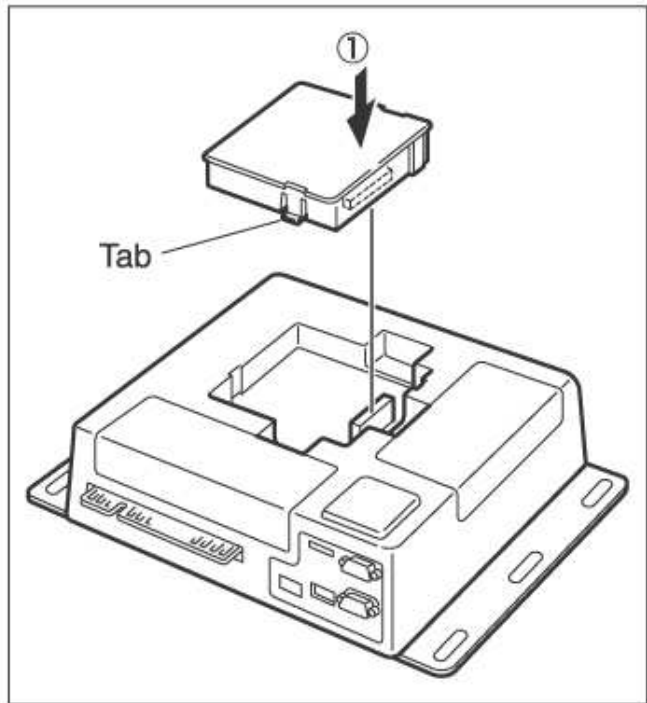

Screen Transition After Insertion

If the ROM cartridge has been inserted correctly, screen transition will occur in the following sequence and the game will then be displayed.

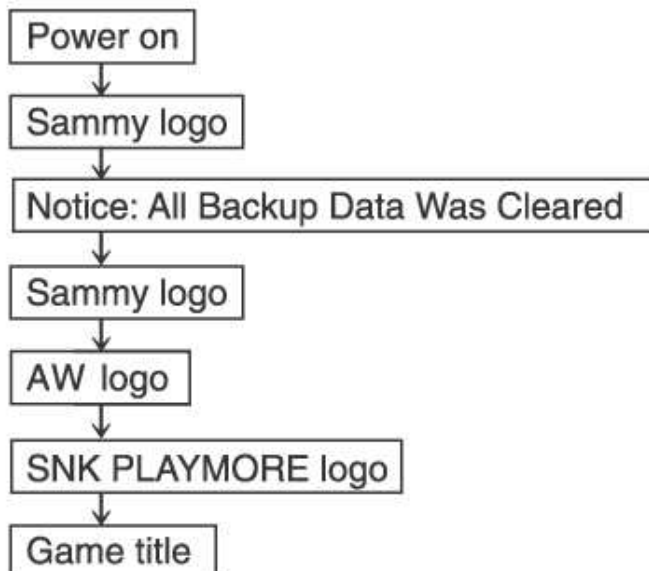

4. How To Play

● Control System

Control Panel

The arrows indicating joystick moves in Command Instructions below are for characters facing right.

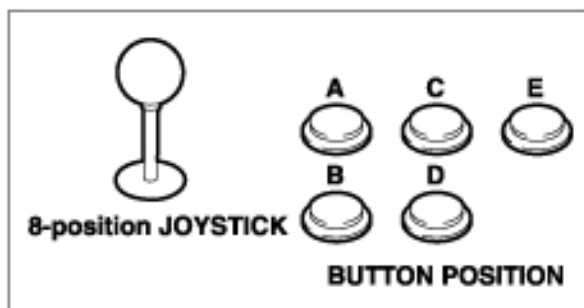

COMMON OPERATION

■ **FORWARD** : →

■ **BACKWARD and GUARD(when an opponent attacking)** : ←

■ **CROUCH** : Push the joystick down ↓, or push it down diagonally to the left or right

■ **JUMP** : Push the joystick up ↑, or push it up diagonally to the left or right

■ **DASH** : →→ quickly

■ **BACK STEP** : ←← quickly

■ **BIG JUMP** : Push the joystick down ↓ briefly then up ↑, or the push it up ↑ and diagonally to the left or right (or push the joystick ↗ during a Dash)

■ **MEDIUM JUMP** : After shifting the joystick down ↓ briefly, push it up ↑ or up ↑ and diagonally to the right, or up ↑ and diagonally to the left (or push the joystick ↗ during a Dash)

■ **SMALL JUMP** : Briefly shift the joystick up ↑ and diagonally to the right or left

■ **LIGHT PUNCH** : Push Button A

■ **LIGHT KICK** : Push Button B

■ **STRONG PUNCH** : Push Button C

■ **STRONG KICK** : Push Button D

■ **ACTIVATES HEAT MODE (★)** : Push Button E when not making attacks or being hit

<★WHAT IS HEAT MODE? >

By pushing the Heat Button when not making attacks or being hit, the player character flashes red and Heat Mode activates. The character's attack strength rises substantially, but life energy, conversely, decreases gradually. Using this when opponents are defenseless or off guard has a devastating effect.

■ **EMERGENCY EVASION(Forward)*** : Shift the joystick to the right → or leave it neutral and push the A & B buttons simultaneously

■ **EMERGENCY EVASION (Backward)***: Shift the joystick to the left ← and push the A & B buttons simultaneously

*Cannot be used in MAX2 Mode.

■ **BLOWBACK ATTACK** : Push the C & D buttons simultaneously

■ **NORMAL BODY SLAM** : Near opponent, → or ← + C or D

■ **BODY TOSS ESCAPE** : The moment you are caught in a NORMAL BODY SLAM, push the joystick right → or push the joystick right ← + the button corresponding to the opponent's body slam attack

■ **FALLBREAKER** : Push the A & B buttons simultaneously before being knocked down

■ **SUPER SPECIAL MOVE** : Enter designated commands (Spends 1 Power Gauge)

4. How To Play

THREE ABILITIES (MODES) TO CHOOSE FROM

In this game each team has 3 types of abilities (modes) at their disposal. Before players select their characters, they must select the mode they wish to use.

★SUPER CANCEL MODE (SC MODE)

Allows a maximum of 3 Power Gauges to be stocked. It's a mode for enjoying orthodox and strategically challenging battles.



SC MODE COMMANDS (Numbers in parentheses represent number of Power Gauges used.)

- **SUPER CANCEL (1)** : Allows input of extra Special Moves or Super Special Moves during specific Special Moves and Super Special Moves.
- **QUICK EMERGENCY EVASION (1)** : Push the A & B buttons simultaneously during a normal move or unique move.
- **GUARD CANCEL EMERGENCY EVASION (1)** : Push the A & B buttons simultaneously while guarding.
- **GUARD CANCEL BLOW BACK ATTACK (1)** : Push the C & D buttons simultaneously while guarding.
- **MAX SUPER SPECIAL MOVE (2)** : Enter designated commands.

★GUARD BREAK MODE (GB MODE)

Allows the stocking of up to 2 Power Gauges. It's a mode for advanced players that provides strong defense and attacks that cannot be guarded against. *Guard Cancel Blow Back Attacks cannot be used in the Guard Break Mode.



GB MODE COMMANDS (Numbers in parentheses represent number of Power Gauges used.)

- **JUST DEFENSE** : Player guards just before an opponent's attack hits.
- **GUARD BREAK ATTACK (1)** : ↓ ↘ → + Push the C & D buttons simultaneously
- **GUARD CANCEL EMERGENCY EVASION (1)** : Push the A & B buttons simultaneously while guarding.
- **QUICK EMERGENCY EVASION (1)** : Push the A & B buttons simultaneously during a normal move or unique move.
- **MAX SUPER SPECIAL MOVE (2)** : Enter designated commands.

★MAX 2 MODE (M2 MODE)

Only 1 Power Gauge can be stocked. It's a simple, easy-to-play mode wherein Power Gauges automatically restore themselves and players can use single-blow MAX 2 attacks. *Emergency Evasion moves cannot be used in the MAX 2 Mode.



M2 MODE COMMANDS (Numbers in parentheses represent number of Power Gauges used.)

- **GUARD CANCEL BLOW BACK ATTACK (1)** : Push the C & D buttons simultaneously while guarding.
- **MAX SUPER SPECIAL MOVE (1)** : Enter designated commands when life energy is at 1/4 or less (appears red).
- **MAX 2 (1)** : Enter designated commands when life energy is at 1/4 or less (appears red).

4. How To Play

● Game Description

This game is a competitive fighting-action game that lets a single player battle against the computer (CPU battles) or two players fight it out with each other (competitive play) with burst-in play. Players select 3 characters to form teams and battle it out. The characters that players can select from and use in battle are listed below.

*Although characters are introduced by team, players are also able to freely create teams to their own particular preference.

PLAYER CHARACTERS

JAPAN Team



KYO KUSANAGI



BENIMARU NIKAIDO



GORO DAIMON

FATAL FURY Team



TERRY BOGARD



ANDY BOGARD



JOE HIGASHI

ART OF FIGHTING Team



RYO SAKAZAKI



ROBERT GARCIA



TAKUMA SAKAZAKI

4. How To Play

IKARI Team



LEONA



RALF



CLARK

PSYCHO SOLDIER Team



ATHENA ASAMIYA



SIE KENSOU



CHIN GENTSAI

WOMAN FIGHTERS Team



KING



MAI SHIRANUI



YURI SAKAZAKI

KOREA Team



JHUN HOON



CHANG KOEHAN



CHOI BOUNGE

KOF'96 Team



IORI YAGAMI



MATURE



VICE

4. How To Play

KOF'97 Team



RYUJI YAMAZAKI



BLUE MARY



BILLY KANE

KOF'98 Team



YASHIRO NANAKASE



SHERMIE



CHRIS

KOF'99 Team



K'



MAXIMA



WHIP

Dream Team



KULA DIAMOND



SHINGO YABUKI



SAISYU KUSANAGI

● Rules

① GAME SUMMARY

■ The goal of this game is for players to select 3 characters from a total of 36 entrants for them to command and win their way through a total of 6 matches.

② MATCH FORMAT

■ Players fight their way through 3-on-3 battles tournament of three-fall rounds.

■ First, the leading member of a team appears to battle for one round. Players exchange attacks and the first player to deprive their opponent of all their life energy wins.

■ The losing character tags off with the second member of his/her team and the victor remains with the life energy remaining from the previous round to battle it out (the victor's life energy may recover slightly with victory and time bonuses).

■ The first team to defeat all 3 members of the opponent's team wins the match.

③ TIME LIMIT

■ The time limit for one round is 60 seconds (actually 50 seconds in real time). When this time runs out, the game ends and the character with the most remaining life energy left wins.

④ DRAWS

■ When the life energy of both opponents simultaneously runs out with a double knockout or when the life energy of both players is the same when time runs out, the round ends in a draw.

■ Characters get one point each for rounds that end in a draw.

⑤ GAME OVER

■ The game ends when one team is defeated by an opponent's team or when matches remain undecided as a result of a draw.

*NOTE 1: ADDITIONAL INFORMATION OF THE TIME LIMIT

It is possible to change the internal actual time values of the time limit using the Game Settings (see p. 15) menu (but although the internal time value can be adjusted to real time through game settings, the time counter of the game's remaining time display remains at unchanged at a function of 60 seconds).

4. How To Play

● Screen Settings



- ① **SCORE**..... Displays the current score.
- ② **STAGE**..... Displays the current stage value (match).
- ③ **TIME COUNTER**..... Displays the remaining time in the round.
- ④ **CHARACTER FACE PLATE**... Shows the face of the character in battle.
- ⑤ **WAITING CHARACTERS**... Displays the faces of characters waiting for battle.
- ⑥ **LIFE GAUGE**..... Displays the remaining life energy for the characters in battle.
- ⑦ **GUARD GAUGE**..... Displays the defensive capabilities of the character and decreases with each attack that hits the character.
- ⑧ **POWER GAUGE (★)**... The gauge increases with each attack and when it becomes full it is used for various actions.

★There are three types of gauge designs for each mode, but the name for the gauge remains the same.

5. System Menus

The ATOMISWAVE System Menu is activated with a push of the cabinet's test switch.

■ **TEST SWITCH** : Select items with the arrow cursor (▶).

■ **SERVICE SWITCH** : Activates the selected item.

*For details concerning the ATOMISWAVE System Menu, refer to the instruction manual for the ATOMISWAVE System Board.

① COIN SETTINGS (SYSTEM MENU → COIN SETTINGS)

The initial settings for the COIN SETTINGS of this software are listed below. Any of these settings can be changed to meet your particular requirements.

■ GAME MODE	: NORMAL
■ COIN CHUTE TYPE	: COMMON
■ COIN #A	: 1 COIN 1CREDIT 1COIN CONTINUE
■ COIN #B	: 1 COIN 1CREDIT 1COIN CONTINUE
■ PRESET SITUATION	: NORMAL

② I/O TEST (SYSTEM MENU → TEST MODE → I/O TEST)

This confirms the operations of the control panel joystick and button connections. This software uses the START button, an 8-position joystick, and the 5 buttons A to E. To exit the I/O test, push and release the SERVICE switch to exit the program.

6. Game Settings

The various game settings can be altered by selecting GAME SETTINGS within the CONFIGURATION mode within the SYSTEM SETTINGS menu of the ATOMISWAVE.

① COMMANDS FOR THE GAME SETTINGS SCREEN

- **TEST SWITCH** ······ Moves the cursor
- **SERVICE SWITCH** ······ Changes the selected item

② GAME ASSIGNMENTS

Allows you to make various game settings.

- **DIFFICULTY** : Determines the strength of the CPU (computer). The initial level is 4.
(EASY) 1 · 2 · 3 · 4 · 5 · 6 · 7 · 8 · 9 (DIFFUCULT)
- **TIME** : Determines the time of a round (actual time). The initial value is 50 actual seconds.
40 · 50 · 60 · 70 · 80 · 90 (seconds in actual time)
- **WINNING LIMITS** : Lets you limit the amount of successive wins. The initial value is "00."
00 · 01 · 10 · 20 · 30 · 40 · 50 · 60 · 70 · 80 · 90
*The 00 setting means there is no limit to successive wins.

■ KEY SETTINGS

- | | | |
|----|---------------------|--|
| 1P | LIGHT PUNCH | PUSH1 : Determines the light punch button for Player 1 |
| | STRONG PUNCH | PUSH2 : Determines the strong punch button for Player 1 |
| | LIGHT KICK | PUSH4 : Determines the light kick button for Player 1 |
| | STRONG KICK | PUSH5 : Determines the strong kick button for Player 1 |
| | HEAT | PUSH3 : Determines the "heat" button for Player 1 |
| 2P | LIGHT PUNCH | PUSH1 : Determines the light punch button for Player 2 |
| | STRONG PUNCH | PUSH2 : Determines the strong punch button for Player 2 |
| | LIGHT KICK | PUSH4 : Determines the light kick button for Player 2 |
| | STRONG KICK | PUSH5 : Determines the strong kick button for Player 2 |
| | HEAT | PUSH3 : Determines the "heat" button for Player 2 |

- **PASSWORD** : You can expand game functions by setting a password. The password consists of 16 characters and can be determined with any letter from A to Z and number from 0 to 9.
- **RETURN TO FACTORY SETTINGS** : Returns various settings in the GAME ASSIGNMENTS to their original factory settings.
- **SAVE&EXIT** : Saves the settings made in the GAME SETTINGS mode and finishes the program.

JAMMA Connector table (with Control panel layout) KOF Neowave



JAMMA EDGE CONNECTOR (56 PINS)

No.	FUNCTION	I/O	No.	FUNCTION	I/O
1	GND	-	A	GND	-
2	GND	-	B	GND	-
3	+5V	IN	C	+5V	IN
4	+5V	IN	D	+5V	IN
5	N.C.	-	E	N.C.	-
6	+12V	IN	F	+12V	IN
7	N.C.	-	H	N.C.	-
8	1P COIN COUNTER	OUT	J	2P COIN COUNTER	OUT
9	1P COIN LOCKOUT	OUT	K	2P COIN LOCKOUT	OUT
10	MONO SPEAKER (+)	OUT	L	MONO SPEAKER (-)	OUT
11	AUDIO OUT	OUT	M	AUDIO GND	-
12	VIDEO RED	OUT	N	VIDEO GREEN	OUT
13	VIDEO BLUE	OUT	P	VIDEO SYNC	OUT
14	VIDEO GND	-	R	SERVICE SW	IN
15	TEST SW	IN	S	TILT SW	IN
16	1P COIN	IN	T	2P COIN	IN
17	1P START	IN	U	2P START	IN
18	1P UP	IN	V	2P UP	IN
19	1P DOWN	IN	W	2P DOWN	IN
20	1P LEFT	IN	X	2P LEFT	IN
21	1P RIGHT	IN	Y	2P RIGHT	IN
22	1P PUSH1 (Light Punch)	IN	Z	2P PUSH1 (Light Punch)	IN
23	1P PUSH2 (Strong Punch)	IN	a	2P PUSH2 (Strong Punch)	IN
24	1P PUSH3 (Light Kick)	IN	b	2P PUSH3 (Light Kick)	IN
25	1P PUSH4 (Strong Kick)	IN	c	2P PUSH4 (Strong Kick)	IN
26	1P PUSH5 (Heat)	IN	d	2P PUSH5 (Heat)	IN
27	GND	-	e	GND	-
28	GND	-	f	GND	-

■ CONTROL PANEL LAYOUT for Generic cabinet

